

Coconut Palm Stem Processing

Technical Handbook

Wulf Killmann and Dieter Fink



protrade
COMPETENCE IN INTERNATIONAL TRADE

Coconut Palm Stem Processing

Technical Handbook



Wulf Killmann and Dieter Fink

Protrade
Deutsche Gesellschaft
für Technische Zusammenarbeit (GTZ) GmbH
Dag-Hammarskjöld-Weg 1-5
D-65760 Eschborn

protrade
COMPETENCE IN INTERNATIONAL TRADE

Imprint

Published by:

Protrade: Dept. Furniture and Wooden Products
Deutsche Gesellschaft
für Technische Zusammenarbeit (GTZ) GmbH
Post-office box 51 80
D-65726 Eschborn
Federal Republic of Germany
Telephone: (00 49) 61 96 /79-0
Fax: (00 49) 61 96/79-74 14
e-mail via internet: protrade@gtz.de

Authors:

Wulf Killmann and Dieter Fink

Photos:

Wulf Killmann and Dieter Fink

On behalf of:

The German Federal Ministry for
Economic Cooperation and Development (BMZ)

Typeset and Print by:

Werbestudio Klein,
Wiesbaden
Brönners Druckerei Breidenstein GmbH
Frankfurt am Main

This manual was printed on
non-chlorine-bleached paper

Nominal fee DM 119,-August 1996

What is Protrade?

Protrade, founded in 1987, is the trade promotion programme of the Deutsche Gesellschaft für Technische Zusammenarbeit (GTZ) GmbH. It works on behalf of and acts within the political framework of the German Federal Ministry for Economic Cooperation and Development (BMZ). Additionally, Protrade also runs trade promotion programmes for the European Commission and other institutions.

Its aim is to contribute to the improvement of competitiveness of private small and medium-sized companies in developing countries and economies in transition, thus generating additional employment and income.

The north-south trade promotion programme and the newly established south-south/regional trade programme cover the following services:

Product Consultancy: product development, design, procurement, production technology, quality assurance and environmental conservation.

Marketing Consultancy: market/trade sector analysis, export marketing, distribution, price structuring; packaging/logistics, special emphasis on sales promotion, advertising and PR measures in the EU.

Trade Fair Consultancy: stand layout, decoration and product presentation; follow-up, organisation and implementation of press conferences; buyer-seller meetings.

Trade Fair Subsidies: for national group stands comprised of at least three companies.

Market Information Service: seminars, workshops; marketing handbooks, export manuals, technical handbooks, trend informations; (83 titles are currently available).

Depending on requirements, and in accordance with the conditions of the European markets, a tailor-made package of measures is conceived for each company. Protrade experts provide on-the-spot advice in over 80 countries and assist in the preparation for trade fair participation in Germany and other EU countries, as well as supporting exhibitors in new business transactions.

Protrade is currently concentrating on the following sectors:

- Textiles, clothing, jewellery
- Fruits, vegetables, fish, flowers, logistics for perishables
- Special cultures, organic products, processed foods
- Shoes, leather, leather products
- Technical products
- Furniture, wooden products
- Home accessories, gifts, toys

The Protrade balance sheet shows the following benchmark data: 34 employees, 650 assignments annually by 305 experts on short-term contract basis, consultancy services rendered to some 1,800 companies in 64 countries, and supported national group stands at 65 European trade fairs.

Protrade is a member of the FORUM of the European Trade Promotion Organisation (TPO) and the Joint Advisory Committee (JAC) of ITC, Geneva. At the present it actively supports 13 joint trade promotion activities of the FORUM members regarding trade promotion, trade fairs, exports and publications.

Contents

	What is Protrade?	3
	Introduction	9
1	The resource	10
	1.1 The coconut palm	10
	1.2 Properties of the palm stem	11
	1.3 Defects in palm stems	16
2	Products and design	17
	2.1 Products	17
	2.2 Design	32
	2.2.1 Preferred jointing and construction techniques	33
	2.2.2 The wood structure as a design feature	39
3	Harvesting and transport	40
	3.1 Felling	40
	3.2 Bucking and skidding	42
	3.3 Loading and transport	46
	3.4 Unloading and log-yard storage	46
4	Primary processing	47
	4.1 Sawing patterns	47
	4.2 Cleaning and ramp-loading of logs	50
	4.3 Break down of logs	51
	4.3.1 Splitting	51
	4.3.2 Handsawing with two-man ripsaw	51
	4.3.3 Chain-sawing	55
	4.3.4 Circular sawing	57
	4.3.5 Band-sawing	59
	4.3.6 Frame-sawing	60
	4.3.7 Comparison of different saws	63
	4.4 Resawing and trimming	64
	4.5 Cutting steels and saw maintenance	64
	4.6 Peeling and slicing	68
	4.7 Chipping for wood-based panels	68
	4.8 Utilization and disposal of waste	68
5	Grading	70
	5.1 Visual grading	70
	5.2 Grading by weight	72
	5.3 Basic density determination	73
	5.4 Pilodyn grading	74
6	Seasoning	75
	6.1 Moisture content assessment	75
	6.2 Stacking	78
	6.3 Drying	80
	6.3.1 Air-drying	80

6.3.2	Kiln-drying	83
6.3.2.1	Solar-drying	84
6.3.2.2	Convection-drying	85
6.3.2.3	Condensation-drying	87
6.3.2.4	Vacuum-drying	87
6.3.2.5	Comparison of different drying methods	88
6.4	Seasoning defects	88
6.5	Seasoning of poles	89
7	Timber protection	90
7.1	Constructive prevention	90
7.2	Wood preservatives	92
7.3	Preservation methods	94
7.3.1	Charring	94
7.3.2	Dip treatment	95
7.3.3	Brushing/spraying	95
7.3.4	Soaking	95
7.3.5	Hot and cold bath	97
7.3.6	Diffusion processes	98
7.3.7	Pressure treatment	100
8	Secondary processing	102
8.1	Introduction	102
8.2	Processing sequences for various products	102
8.2.1	Frame door with panelling	103
8.2.2	Chair back leg	105
8.2.3	Parquet block	106
8.2.4	Turned components	107
8.2.5	Laminated table-top	108
8.3	Effects of the properties of the wood on its machinability by cutting methods	109
8.4	Basics of wood machining	112
8.5	General remarks on tool and machine design	115
8.5.1	Machine characteristics	115
8.5.2	Tool characteristics	117
8.6	Machining methods in secondary processing	120
8.6.1	Sawing	120
8.6.2	Narrow band-sawing	128
8.6.3	Planing (Peripheral flat planing)	132
8.6.4	Profiling/moulding	138
8.6.5	End-face planing (hogging)	146
8.6.6	Boring	148
8.6.7	Sanding	151
8.6.8	Mortising and tenoning	155
8.6.9	Dovetailing	158
8.6.10	Swing chisel mortising	160
8.6.11	Lathe-turning	162

8.7	Gluing technique	165
8.8	The finishing of coconut palm wood	167
8.9	Summary of machining conditions	
	For the important cutting methods for coconut palm wood	169
8.10	Sequence to determine machining conditions	171
9	Energy from coconut wood	173
9.1	Firewood	173
9.2	Charcoal	173
10	Economics	177
10.1	Profitability	177
10.2	Calculation of costs for cut timber from coconut palm wood	180
	10.2.1 Capacities	180
	10.2.2 Calculation of manufacturing costs	181
10.3	Cash-flow analysis and internal rate of return of a coconut palm wood furniture plant	183
11	Marketing	185
12	Checklist: How to start coconut palm stem utilization	188
13	Glossary	190
14	List of Tables	194
15	List of Figures	196
16	List of Photos	199
17	Abbreviations	201
18	Literature cited	203

Introduction

More than 560 papers have been published on this subject (Killmann et. al.,1988). The present brochure is not intended to compete with these but rather to give interested parties practical advice on how the palm stem can be used. Based on their own experience and on a critical screening of the literature the authors sum up the state of the art on coconut palm stem utilization. Many of the technical and scientific terms are explained in the glossary.

1 The resource

1.1 The coconut palm

Cocos nucifera L, the coconut palm, is an agricultural crop widely spread throughout the tropics. It has been cultivated by man for 4000 years. The main produce is copra, the dried kernel of the nut. Converted into oil, it becomes the base for a wide range of products, from cooking oil to soap and shoe polish.

Traditionally, coconut palms were found around hamlets in the tropics, in rather small stands to provide the villagers with basics such as:

- vegetable fat (from copra)
- roofing material (leaves)
- ropes and strings (coir from the husks)
- beverage (coconut juice)
- alcoholic drink (from the inflorescence - tuba or toddy)
- fuel (from the husks and nuts)
- timber (from the stem).

At the end of the last century, coconut palms were planted in larger plantations, especially in the Pacific and on the Philippines, Ceylon, East Africa and the Caribbean, for large-scale copra production. Presently, more than 10 million ha are worldwide under coconut palms. According to stem height, tall and dwarf varieties are distinguished. 45 tall and 18 dwarf varieties are known. All older plantations are planted with tall varieties. Once these palms are 50 - 60 years old the copra yield declines rapidly. When the plantation-grown palms reached this age in the 1960s, replanting programmes were developed and the question of economic removal and disposal of old palms arose.

Removal was necessary in order to make space for new plantations. If the material was left to rot, the rhinoceros beetle (*Oryctes rhinoceros*) would start to breed in the decaying material and attack the young seedlings. Subsequently, various coconut-growing countries started to investigate the economic disposal or use of the stem. The research activities started were partly funded and backed by the governments of New Zealand and the Philippines, as well as by the FAO (Food and Agriculture Organization of the United Nations). In Zamboanga, Philippines, a research station was established and the utilization of the coconut palm stem as a timber resource was assessed and proven.

Table 1: Palm stem data (at 60 years of age)

Diameter max. (butt)	30 cm
Diameter (top)	15 cm
Height about	20 m
Gross volume per stem	0.9 m ³
with ca. 100 palms/ha	90 m ³ /ha

(Average values, dependent on age, site and variety.)

1.2 Properties of the palm stem

Although inappropriate, the term "coconut wood" has been established for the material of the coconut palm stem, and will therefore be used in this handbook as well. Unlike "conventional" trees, palms, like many other monocotyledons, have vascular fibre bundles (red-brown spots on a cross-section) scattered in a yellowish parenchymatic ground tissue. These bundles contain the water and nutrient transport system (xylem vessels and phloem) as well as thick-walled fibres giving the stem its strength, and paratracheal parenchymatic cells. The ground parenchyma has mainly a storage function and contains starch among other things. The anatomical features result in a rather non-homogenous distribution of physical properties both over cross-section and height, and thus in a very non-homogenous raw material. Principally, the density decreases towards the centre of the stem, and over stem height. Figure 1 gives a qualitative impression of the density distribution over the stem from five 80-year-old Philippine palms, Photo 1 shows its distribution (dark = high density) over a cross section.

Fig. 1: Schematic density distribution in mature coconut palm stem

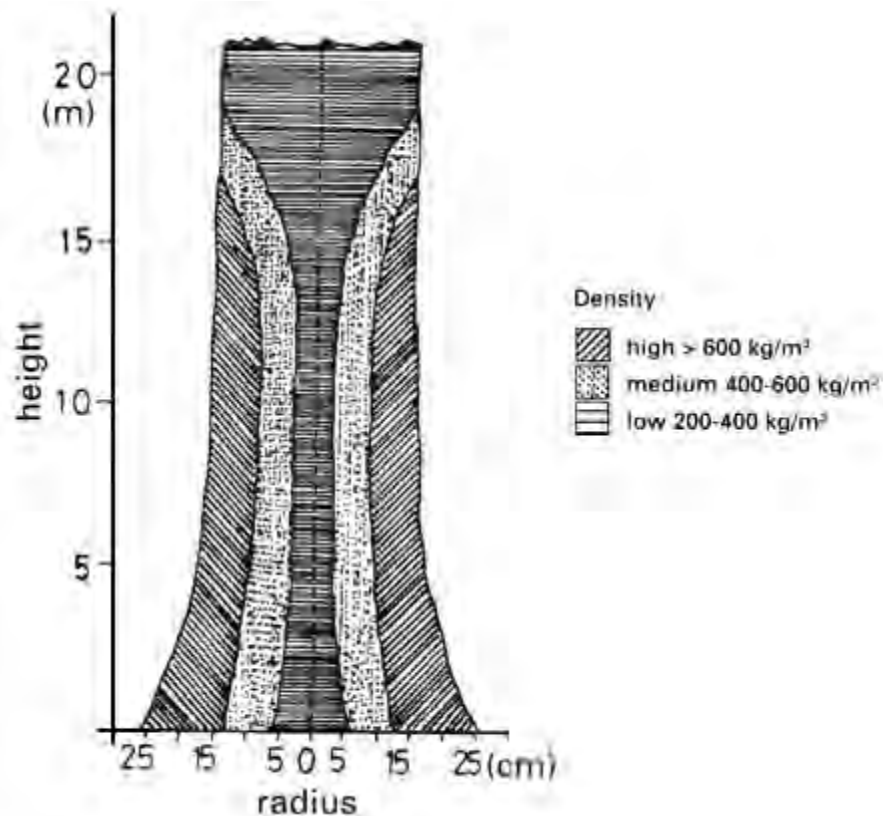

Photo 1: Cross section of coconut palm stem at breast height



The actual distribution may differ in each palm according to variety, site, and age. However, due to the absence of rays, differences of properties in tangential and radial direction, as they exist in conventional timbers, are negligible. Oven-dry density ranges from 0.85 g/cm^3 at the lower periphery to 0.11 g/cm^3 in the pith at the top end. Initial moisture content, on the other hand, increases in the same directions, with lowest values at the bottom periphery (50 %) and highest (up to 400 %) in the stem centre at the top (Killmann, 1983).

Figure 2 shows the potential uses of different stem parts.

Fig. 2: Use of the coconut palm stem

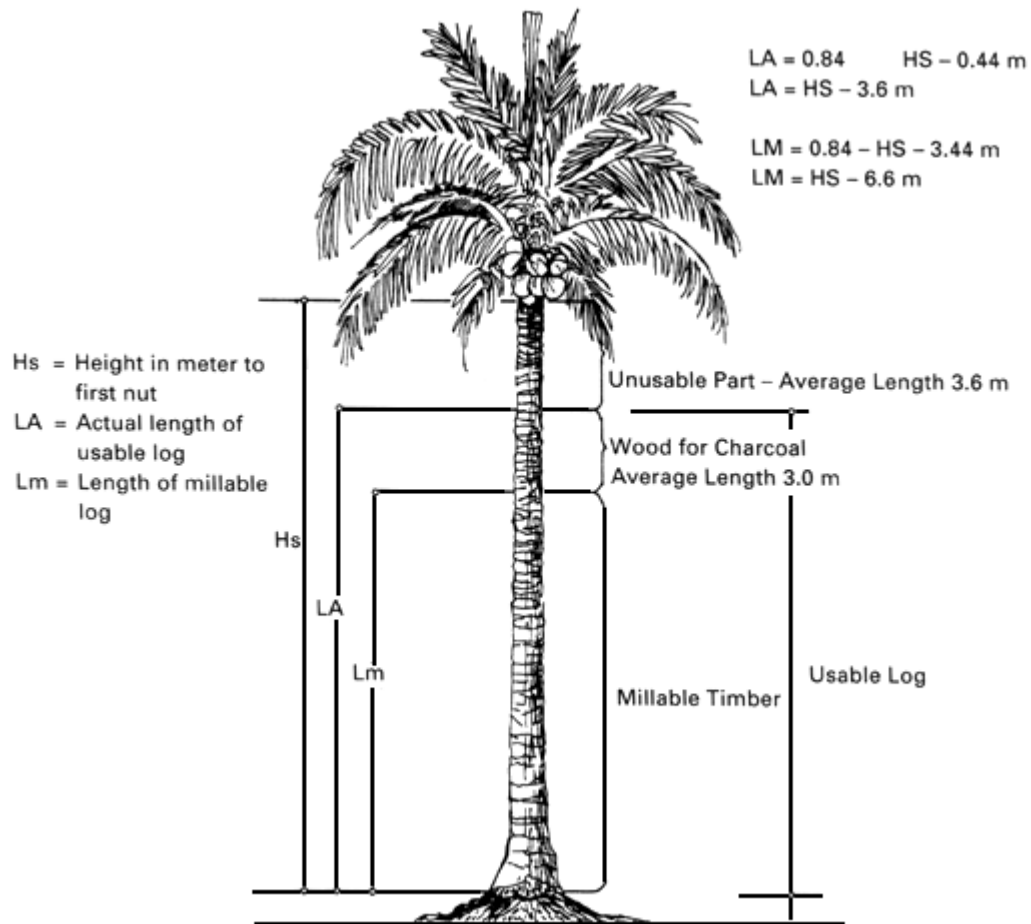

Depending on its oven-dry density, coconut wood can be segregated into three different groups (Figure 3):

High density timber (HD)

(> 0.6 g/cm³)

Timber from lower periphery of stem. Can be used for load-bearing structural purposes, framing, flooring, staircases, tool handles, furniture.

Medium density timber (MD)

(0.4-0.59 g.cm³)

Timber from upper stem periphery and lower middle section. Used for limited load-bearing structural purposes, furniture, wall-panelling, curios.

Low density timber (LD)

(< 0.4 g/cm³)

Timber from core sections. Indoor use only, where no load is applied, e.g. wall-panelling.

Fig. 3: Cross section of coconut palm stem with density zones

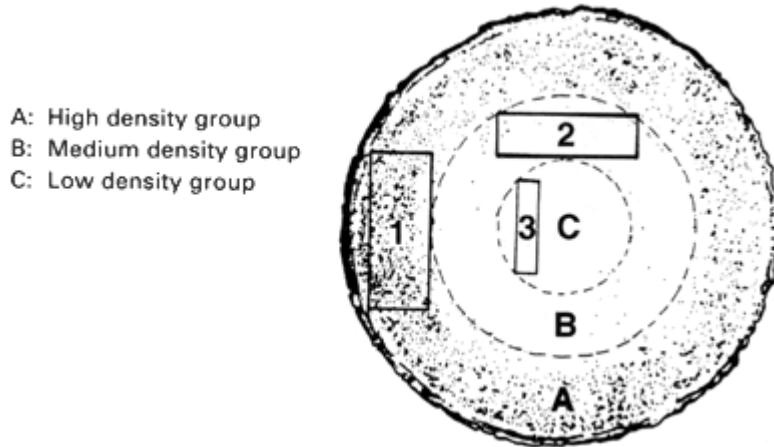

Only when palms are over 60 years of age (that is, when the copra yield declines, and they are of less interest to the farmer), is enough "wood" built up and therefore of use to the sawmiller. This implies that there is no conflict between the use of the palm for its primary production (oil and fat) and the later stem use for timber. On the contrary: the use of the timber generates a windfall profit to the farmer.

It also implies that only stems of tall varieties can be used for timber, not those of dwarf varieties.

The percentage of the various density groups per stem depends on variety, site, age, sweep of palm, human impact {harvesting step, Figure 4), and the extent of fungus and insect damage.

Fig. 4: Harvesting steps in coconut palm stem

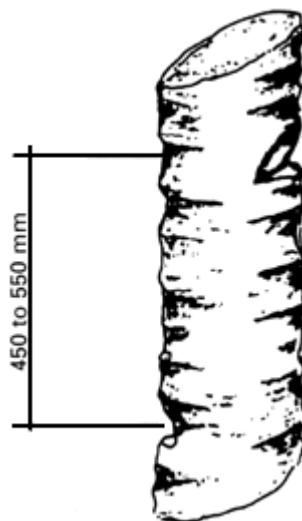

With 80-year-old palms of the San Ramon Tall variety in Zamboanga a distribution of

High density 40 - 50 %
 Medium density 20 - 30 %
 Low density 20 - 30 %

was observed.

All mechanical properties which define the use of a timber are closely related to its density (weight/volume at given moisture content). This inhomogeneity influences the methods of processing as well as the uses for the coconut palm stem. Sulc (1983, 3) has assessed the mechanical properties for the different density groups {Table 2} of 80-year-old coconut palm stems from Mindanao, Philippines.

Table 2: Mechanical properties of coconut wood, 12 % mc

Basic density (g/cm ³)	0.25 - 0.39	0.4 - 0.59	>0.6
Strength (MPa)			
Modulus of elasticity	3633	7116	11414
Modulus of rupture	33	63	104
Compression parallel to grain	19	38	57
Shear	n.a.	8	13

Source: Sutc, 1983, 3

1.3 Defects in palm stems

Coconut palms are attacked by insects (rhinoceros beetle, palm weevil), mycoplasma-like organisms, and fungi.

Insects usually attack the growing point of the palm, reduce its vitality and finally lead to its death. Rhinoceros beetle attack can easily be detected visually. It results in palm fronds being cut in a diamond-shape.

Mycoplasma-like organisms attack the phloem and clog it. They result in the final death of palms. The diseases are known as Lethal Yellowing and Cadang-Cadang.

Fungi usually attack the palm stem, when its vitality is diminished due to insects or mycoplasma-like organisms, or after physical damage, be it through hurricanes, or due to human impact. While the other two agents have no direct impact on the timber quality, fungal attack does. Most commonly fungi find entrance into the stem through harvesting steps cut into the outer, hard portion of the stem in some countries in order to facilitate harvesting of the nuts (Figure 4). Rainwater and dirt collect in the wounds, and fungi (and later also insects like termites) find their way into the stem and feed on the parenchymatic tissue. The attack appears as brown spots on a cross cut or as a string spot on a longitudinal cut, where the parenchyma is gone and only the bundles remain intact. This attack reduces both the properties as well as the appearance of the timber.

2 Products and design

2.1 Products

Taking certain pre-conditions into account, almost the entire stem (trunk) of the coconut palm tree can be used to manufacture structural components, furniture and other utility articles.

The essential things that must be considered are:

- density group and wood structure
- the climate where it is to be used
- the woodworking conditions.

The three density groups discussed in the first chapter must be taken as a basic pre-condition in utilization. A list of recommended uses is given in Table 3.

Table 3: End-uses for coconut wood

Use	Density group		
	High	Medium	Low
Structural			
- loadbearing	x		
- studs, beams	x		
- roof trusses	x	x	
- gangnail trusses	x	x	
- glulam beams	x	x	
- floor joists	x	x	
- internal members	x	x	
Door and window frames	x	x	
Staircases	x	x	
Stairs	x		
Flooring	x		
Parquet	x		
Wall-panelling (t & g)	x	x	x
In/outside cladding	x	x	x
Roof shingles	x	x	
Furniture	x	x	(x)
Tool handles, tools	x		
Kitchenware, bowls	x	x	
Turned products	x	x	
Curios	x	x	
Crates, pallets, boxes	x	x	x
Charcoal	x	x	
Briquettes			x
Transmission poles		round, hollow stem	
Fence posts		quarter split, upper third of stem	

As can be seen in Table 3, wooden products are manufactured mainly from medium-density and high-density coconut palm wood. The low-density wood does not achieve adequate strength values and surface qualities and therefore has only a very limited range of uses.

Basically it is true to say that apart from a few exceptions (e.g. bentwood parts for furniture), all of the classical solid wood products can be processed from coconut palm wood. As with all other types of wood, it is necessary to take into account the fact that coconut palm wood must be dried down to a wood moisture content corresponding to the surrounding atmosphere (= a function of the prevailing air temperature and air humidity). For example this wood moisture content is about 8% for wood used in heated rooms. Such wood moisture content values are achieved only by kiln-drying of the kind described in Chapter 6.

A further criterion that must be taken into account when using coconut palm wood is its limited resistance to weathering. It is usable to only a limited extent for products in the outdoor area. In addition to design (structural) protection of the wood, chemical wood protection is indispensable when using palm wood out of doors.

The possibilities for using coconut palm wood will be demonstrated below with the aid of photographs from various areas of use.

Coconut wood has been successfully used to build houses of different standards (low-cost - Photos 2, 3 - as well as executive-type), for industrial and office construction as well as buildings for recreation (Photo 4) and worship (chapel) in Zamboanga and Davao, Philippines (Photo 5). In executive houses (Photo 6), e.g., all structural parts are made out of coconut wood. Where exposed to weathering, they have been treated before construction. The coconut wood framework is, on the inside, covered with tongued and grooved (t & g) coconut wood boards, the outside is covered with pressure-treated coconut wood panelling (Photo 7). Stairs and floors as well as door- and window frames (Photo 8) are made of high density coconut wood. The porches are ornamented with turned coconut wood balusters (Photo 9). Attractive furniture and accessories for offices, living-rooms and classrooms have been manufactured (Photos 10, 11,12,13, 14,15,16, 17). Tool handles of coconut wood are in use (Photo 18), as well as fence posts (Photo 19), house posts, transmission poles (Photos 20, 21) and crates (Photo 22).

Not feasible:

- face veneer for plywood (coconut veneer sheets disintegrate during drying).

Technically feasible but uneconomical:

- manufacture of pulp and paper
- manufacture of chipboard and fibreboard (recovery too low due to high percentages of fines and high consumption of glue/resin).

Important

- Never use low density material for construction!
- Timber exposed to weathering should always be treated!
- The wood must be dried to a wood moisture content corresponding to the climate in which it is to be used!

Photo 2: Low-cost house



Photo 3: Handplaning of coconut beam for low-cost house construction



Photo 4: Coconut pavilion roofed with coconut shingles



Photo 5: Roof construction of coconut chapel in Davao, Philippines



Photo 6: Bungalow with coconut wood - the pillars are hollow cylinders



Photo 7: Detail of wall with bricks made of coconut sawdust and wall-panelling



Photo 8: Details of coconut wood house (window frames)



Photo 9: Turned balusters



Photo 10: Chair



Photo 11: Laminated table-top



Photo 12: Briefcase



Photo 13: Dining-room table and chairs (Pacific Green, Fiji)



Photo 14: Coconut wood - upholstered furniture (Pacific Green, Fiji)



Photo 15: Living-room furniture and accessories (Pacific Green, Fiji)



Photo 16: Coconut palm wood furniture exhibited at International Furniture Fair in Cologne, 1994



Photo 17: Coconut palm wood furniture exhibited at International Furniture Fair in Cologne, 1994



Photo 18: Tool handles



Photo 19: CCA-treated fence post



Photo 20: CCA-treated power pole



Photo 21: Fungal attack on untreated power pole



Photo 22: Crates



2.2 Design

The machining of coconut palm wood is rendered difficult by the structure of the wood. For cost reasons these difficulties must already be taken into account during design (see also Table 4), otherwise processing may become uneconomic and the products do not have the required qualities. The effects of the properties of the wood on its processing during the machining operation are listed in Chapter 8.

Table 4: Design guidelines for industrially manufactured products

Problematic:	To be Preferred
Designs and jointing techniques that require a large proportion of manual	Designs and jointing techniques that can be carried out by the use of
Mortise and tenon joints	Dowelled joints, if strength is
Profiles with a large material removal volume/large profile	Profiles with a small material removal volume/small profile
Dovetail joints/Finger joints	Dowelled joints
Frames with a counter profile	Frames with mitre joint
Edge radius < 5 mm	Edge radius > 5 mm
Highly profiled lathe-turned components with a profile base narrowing to a point	Lathe-turned components with small profile projections and a profile base narrowing to a rounded shape (circular rods, hollow
Absolutely to be avoided:	
Highly profiled cross-grain wood	Non profiled cross-grain wood with rounded edges
Finger joints	Longitudinal wood joints with dowels or tongue

The fact that the strength properties of coconut wood are lower compared to other wood species of the same density classes must be taken into account in the design and jointing techniques for a product. This is especially true for all wood joints in which there are glue bonds between the connecting longitudinal and transverse wood surfaces. The dowel led joint, which has distinct advantages in its manufacture, is especially critical here unless adequate precautions are taken to avoid the known negative factors. Even with coconut wood, however, the dowelled joint can achieve the strengths required in the construction of furniture, windows and doors provided that appropriate precautions are taken.

With regard to strength properties, the mortise and tenon joint, especially the double mortise and tenon, is superior to the dowelled joint. The reasons for this are the large glued areas and the fact that it involves mainly an adhesive bond between the longitudinal surfaces of the wood. However, the mortise and tenon joint has significant manufacturing technology disadvantages compared to the dowelled joint (in this connection see Chapters 8.6.6 and 8.6.8).

2.2.1 Preferred jointing and construction techniques

Dowelled joint

The dowelled joint is a simple and universally usable joint. It is used as a frame corner and box corner joint. When using coconut wood, adequate strength values are achieved if the glue is adjusted to a high viscosity and/or the glue is applied several times, especially in the cross-grain wood region, so that excessive absorption of the glue does not occur (starved glue line). This also applies to dowel holes, which have a high proportion of cross-grain wood, depending on the position of the drilled hole. In addition, in the case of jointing surfaces in the cross-grain wood region, special care must be taken to ensure that there are no raised vascular bundles that prevent an accurate, tight joint fit. Figures 5,6 and 7 show the principle of dowelled joints. The dowel spacing distances should not exceed 120 mm.

Fig. 5: Principle of a dowelled joint

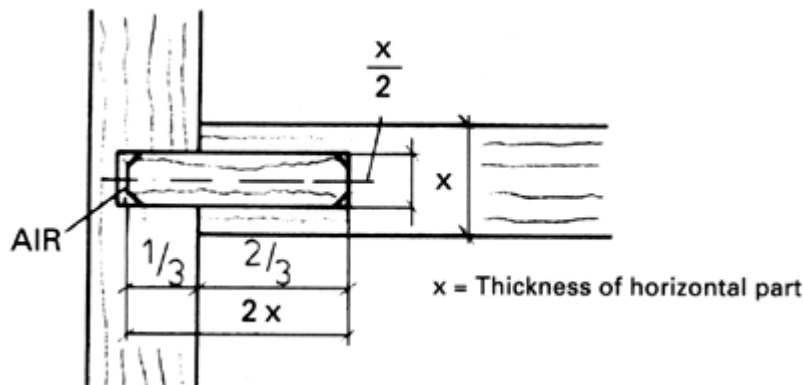
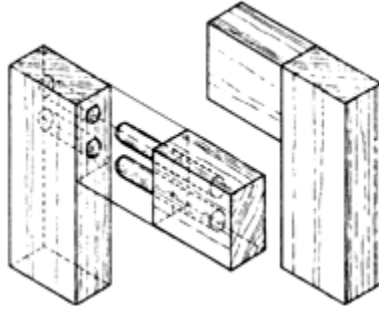

Fig. 6: Butt-dowelled frame corner

Longitudinally profiled components are particularly suitable for mitred corner joints.



Source: Nutsch, 1983

Fig. 7: Dowelled mitred frame corner

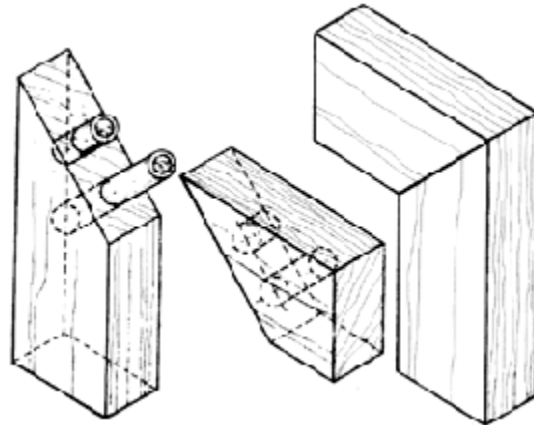

Source: Nutsch, 1983

Tongue and groove joint

The tongue and groove (t & g) joint is simple to machine. An inserted tongue (extraneous tongue, lamello) should be used in the construction of tongue and groove joints in coconut wood to avoid pronounced splintering. The same points as in the case of the dowelled joint apply in regard to glue adjustment and application rate and the joint fit (raised vascular bundles). Figures 8 and 9 show the principles of tongue and groove joints.

Fig. 8: Principle of a tongue and groove joint

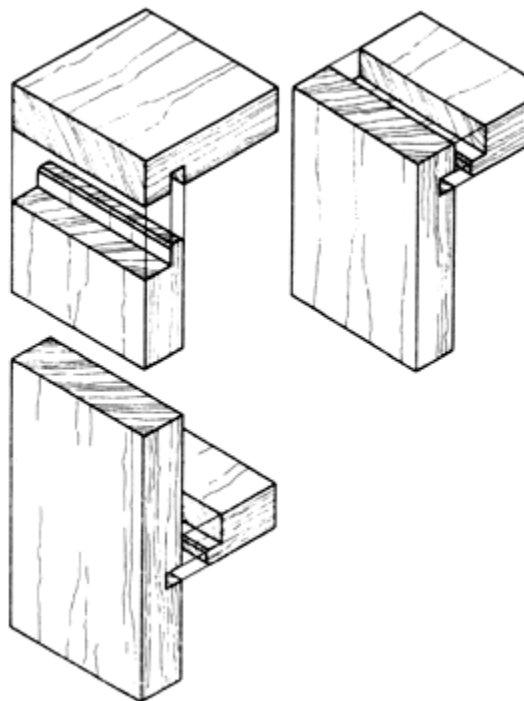

Fig, 9: Tongue and groove joint with inserted tongue

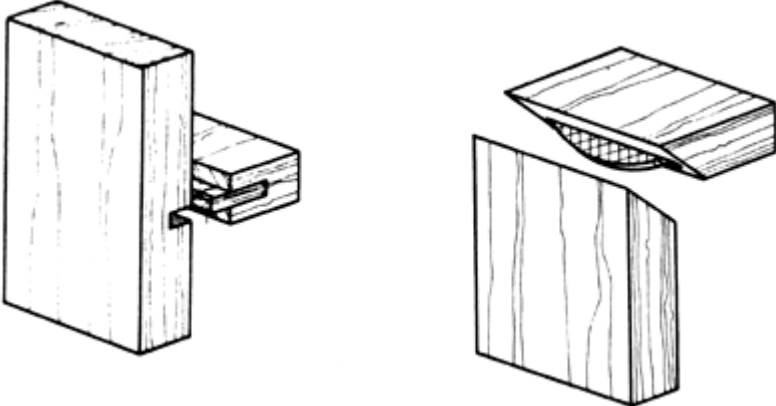

Source: Nutsch, 1983

Laminated material

It is possible to design furniture of panel construction with coconut palm wood by means of solid wooden panels (glue-laminate wood panels). The panels are manufactured by gluing wood strips together in the width (see Figure 10). Gluing the strips in the length using finger joints is a problem with coconut palm wood (see Section 8.6.9). The dowelled or tongue and groove joint in the cross-grain wood region is recommended as a jointing principle for longitudinal joints. Strict adherence to the density class is necessary when selecting the wood. Otherwise the panels warp or dissimilar shrinkage and swelling effects occur between the bonded wooden strips. In addition to using the same density class in a single glue-bonded component (panel, squared timber, beam), attention should be paid to uniformity of colour among the individual elements (strips) that are to be glued together. It is also advisable to pay attention to the number of vascular bundles in a surface unit, since these affect the optical and strength characteristics {see also the following section 2.2.2}.

Laminated beams of the kind used to achieve load-bearing building structures and rather large spans or structural component lengths can be manufactured using coconut palm wood (see Photos 23 - 26). Because of their poor weathering resistance, they are usable only in a protected environment (in this connection see Chapter 7).

Fig. 10: Glue-bonded profile for full-width bonding

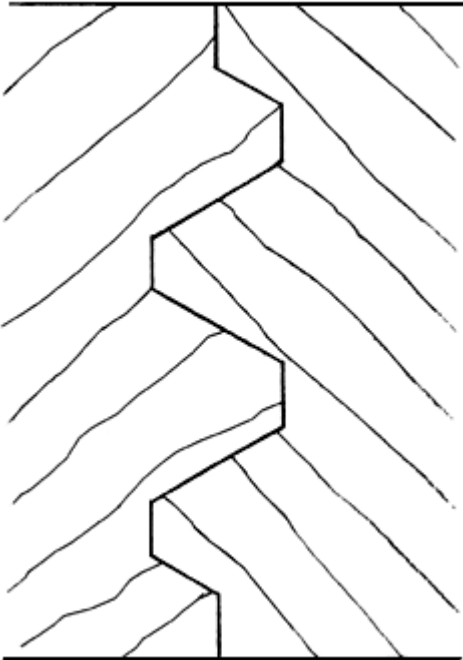

Photo 23: Laminated and bolted coconut boards



Photo 24: Laminated roof trusses joined by a nail plate



Photo 25: I-beam with plywood webbing



Photo 26: Laminated and bolted roof construction



Hollow cylinder

A further design alternative is offered by sections of coconut palm trunks lathe-turned circular on the outside and centre-bored to an internal diameter of approx. 170 mm. These hollow cylinders (tubes) can be used structurally and decoratively, either as a whole or divided lengthways. Examples of their use include: cheeks and side-pieces for shelves or wall units, side-pieces for the supports of chairs and tables, posts, beams or trusses for wooden structures of all kinds (see also Photos 6,14, 15, 16). As a result of this tube principle, high strengths can be achieved, far exceeding the strengths of the massive material (the trunk as a solid cylinder). Another advantage is that drying cracks are prevented, which occur when drying material with different density areas.

2.2.2 The wood structure as a design feature

In addition to its colour, the texture of coconut palm wood is also a conspicuous feature (see Figure 11). The intensity of the vascular bundles stands out to an extent that varies depending on the position in the trunk. They decrease towards the centre of the trunk and towards the top. In a longitudinal section the vascular bundles are as a rule seen as lines running more or less parallel. In a cross-section they appear as dark points in the light-coloured parenchyma tissue. In a diagonal section they appear as short, thick lines. Depending on the arrangement of the different graphical forms of the vascular bundles in the product, an aesthetic image is formed that contrasts with the inherent simplicity of the coconut palm wood.

Fig. 11: Vascular bundles in longitudinal, transverse and diagonal section



longitudinal

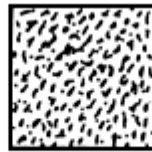

cross-section



diagonal

Source: Rossmann, 1994

Important

- Cross-grain wood surfaces should not show any raised vascular bundles in the joint region; they must be absolutely flat and smooth!
- The adhesive should be adjusted to a high viscosity (especially when applying to cross-grain wood surfaces); alternatively the adhesive should be applied several times, in dowel-holes as well!

3 Harvesting and transport

The different steps of harvesting and transport operations can be identified in the following flowchart:

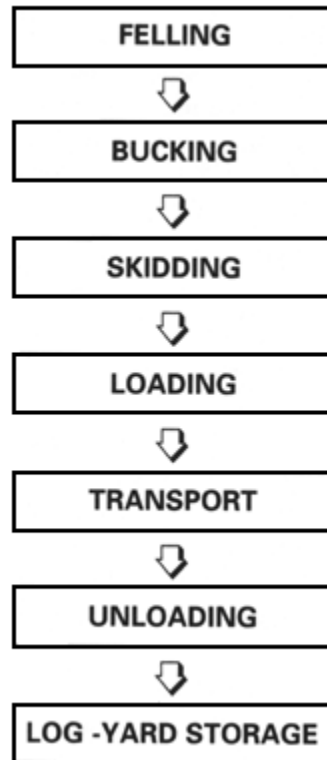

3.1 Felling

Smaller numbers of palms can be felled by axe or with a two-man saw. However, due to the abrasive effect of the sclerenchymatic fibres in the bundles, the saw has to be resharpened often and the procedure of felling is tedious and slow. For clear-felling it is advisable to use a chain-saw with a 60 cm guidebar and chipperchain. A two-man team (operator and assistant), equipped with chain-saw, axe, machete, wedges, repair kit, and medical kit, needs 2-3 working days (4-6 man-days) to fell one hectare, thus yielding about 90 m³ of coconut stems. The basic felling principles are shown in Figure 12.

Fig. 12: Felling of coconut palms

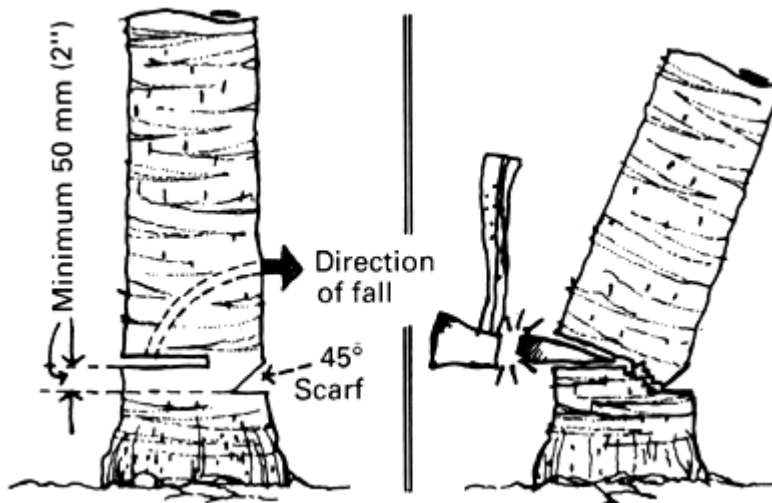

Source: PCA, 1977

Important

Fell all palms in one direction in order to facilitate their removal

The palms should be felled as close to the ground as possible in order to reduce the size of the stumps left behind. With larger stumps the danger of rhinoceros beetle infestation increases. The lower the stumps are, the easier they will be covered by the cover crop (usually a legume) and hence decay, thus adding to the fertilization of the plantation.

If the stumps are to be removed as well, the palm has to be topped by heavy equipment, e.g. a bulldozer. This can be done either by bulldozing through the roots, previous manual cutting of the roots (Figure 13), or by just toppling the palms with a bulldozer. However, if the palm is felled in this way (Photo 27), additional costs arise in disposal of stumps (useless for further processing) and in levelling of the plantation. Therefore, it is recommended to leave the stumps in the ground and plant the new palms between the old rows.

Fig. 13: Bulldozing through palm roots

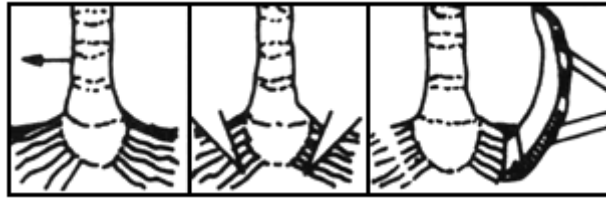

Source: FAO, 1985

Photo 27: Coconut palm stems after topping



3.2 Bucking and skidding

After felling, the top portion of the palm (3 m below crown) is to be cut off. The method of hauling depends on the type of equipment available as well as on the scale of operation. If the stems are to be pulled out by draught animals (oxen, donkey, horse, water-buffalo), the stems have to be cross-cut (bucked) to a shorter length at the plantation in order to reduce the load for the animals (Figure 14). The length of the logs cut depends on their later use. The logs must be marked on their lower end after bucking in accordance with their position in the stem, i.e. bottom log (1), middle log (2), top log (3) etc., because the quality of lumber also depends on its vertical position in the stem. The marking facilitates later grading (Figure 15).

Fig. 14: Skidding behind horse

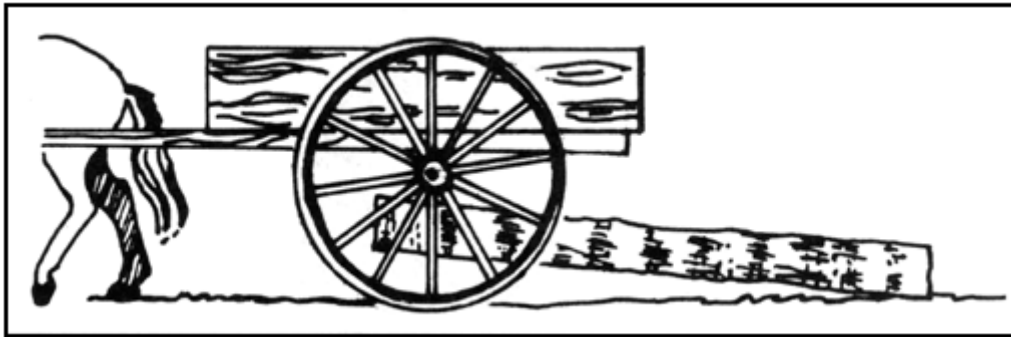

Source: FAO, 1985

Fig. 15: Marking of logs in field

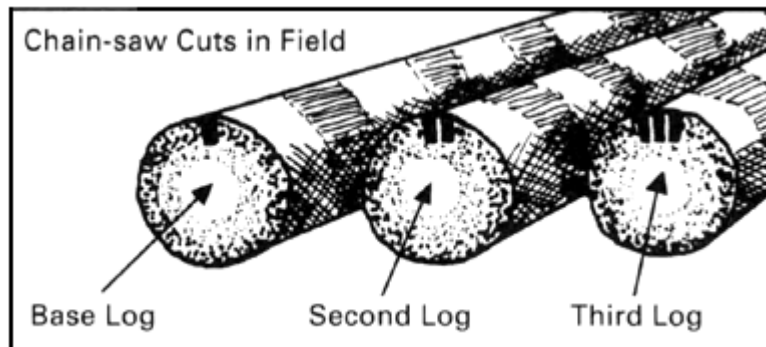

Source: FAO, 1985

If agricultural tractors are available, two methods can be applied for skidding:

Method 1:

The tractor is stationary at the collecting point. The entire stems are pulled out by means of a winch (yarding method) connected to the tractor's power takeoff.

Disadvantage: The stem ploughs through the ground while being pulled, it collects mud and grit, which facilitates decay and makes later sawing more difficult.

Method 2:

The entire stem is pulled by the tractor, bottom first, with the help of a chain and a skidding bar fitted to the hydraulic lift of the tractor. The skidding bar can easily be manufactured locally from mild steel. For lifting the stem, a normal chain will do (Figures 16, 17).

Advantage: The stem is lifted at the front end, and only the top portion slides over the ground and collects dirt.

Fig. 16: Skidding bar

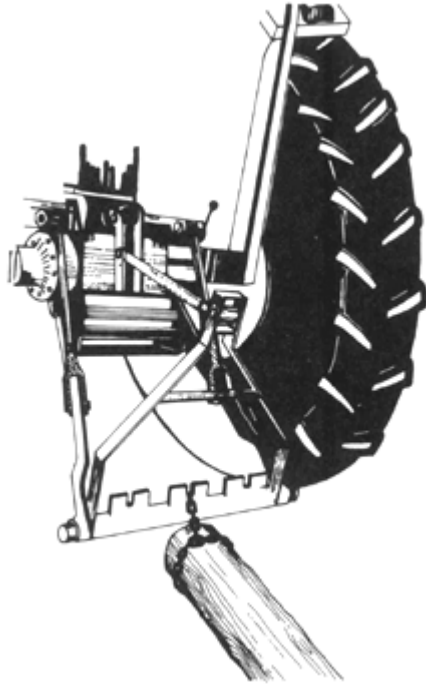

Source: Jensen, 1981

Fig. 17: Skidding by tractor

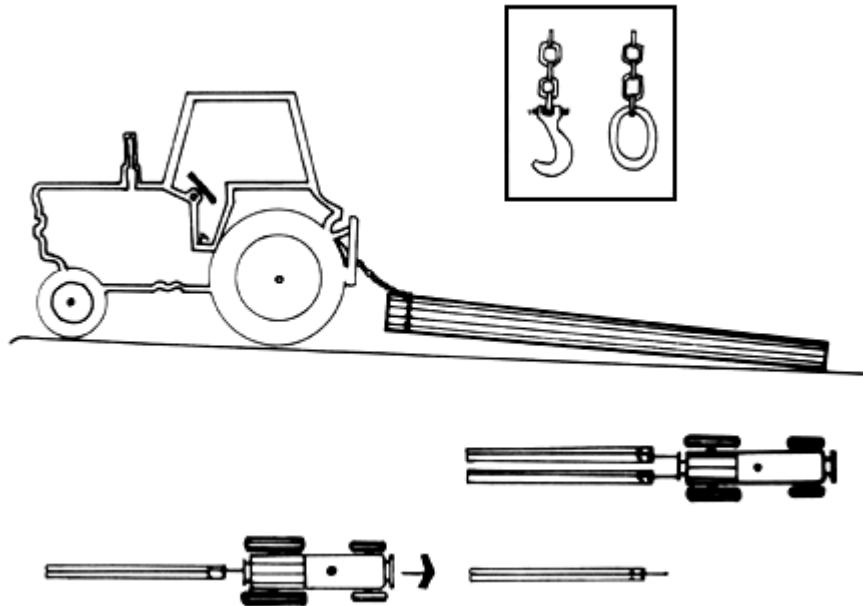

Source: Jensen, 1981

At the collecting point or landing, the stems are cross-cut (bucked) according to the length required, usually 5-6 m (Figure 18). The length depends on the end-use of the timber. It is obvious that in order to achieve highest recovery, a stem with strong sweep is cross-cut into shorter logs than one with a straight bole.

In situations where the stems are to be used as transmission poles, only straight, sound palms should be selected and cut to the appropriate length.

Fig. 18: Bucking of coconut palm stems

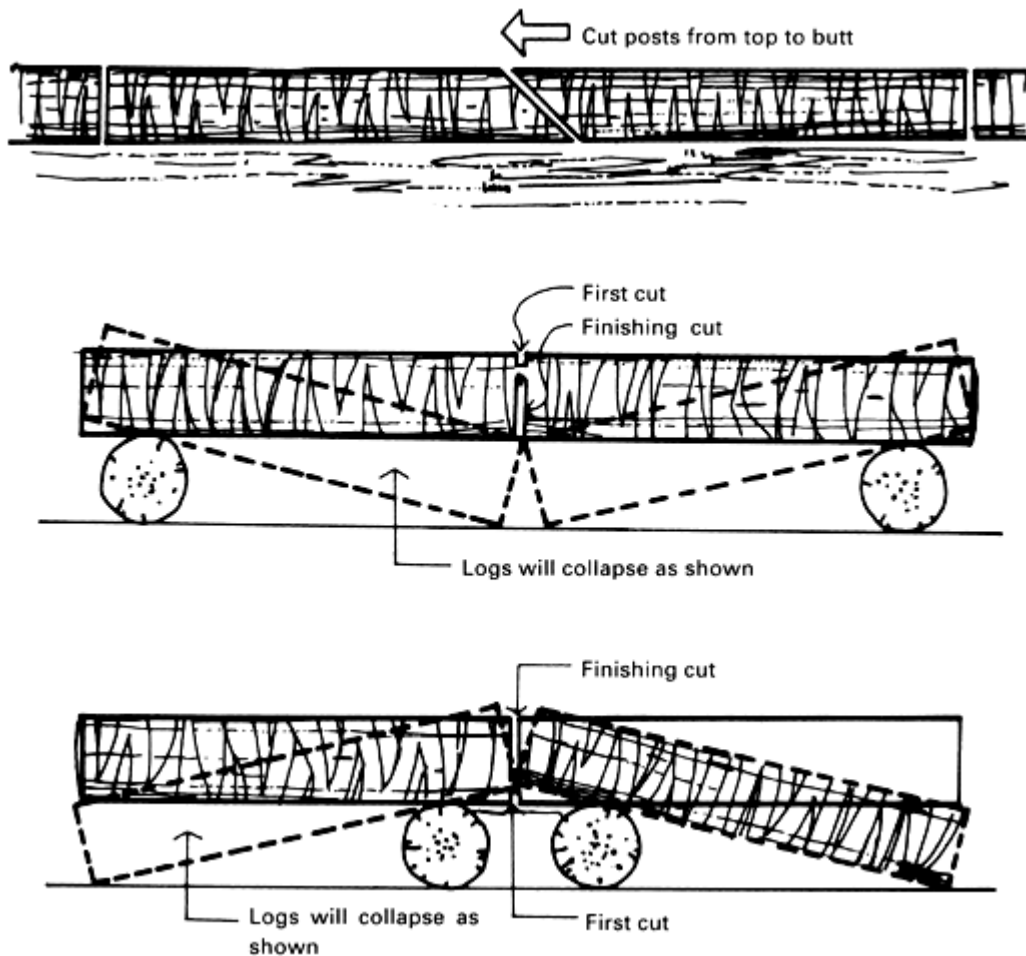

Source: PCA, 1977

3.3 Loading and transport

The means of transportation to the sawmill depends on the amount of stems to be transported and on the distance to be covered. Oxen or buffalo driven carts, flatbed trucks, or four-wheel bunk-trailers towed by agricultural tractors can be used. Loading can be done with the help of an agricultural tractor with a forklift. Another possibility is the construction of a slide, made from shorter upper ends of the coconut palm stem, leading to the trailer platform. The logs can then be pulled over this slide with ropes and the help of draught animals stationed on the opposite side of the vehicle.

Important

Swift removal of the palms from the plantation and landing is essential in order to reduce the danger of decay!

3.4 Unloading and log-yard storage

The unloading at the log-yard can be done manually, over a slide made of smaller coconut logs, or with the help of a forklift tractor. The log-yard should be dry and well drained. **All** vegetation should be removed and the area either gravelled or cemented. This is important to reduce the danger of insect and fungal attack during storage. Also, in order to minimize this danger, the storage time in the log-yard should be as short as possible. A water tap should be close by to allow the washing off of any dirt and grit of the logs before sawing.

Remember

Logs are easier sawn when still wet. Dirty logs blunt the tools faster.

4 Primary processing

The steps connected with primary processing are:

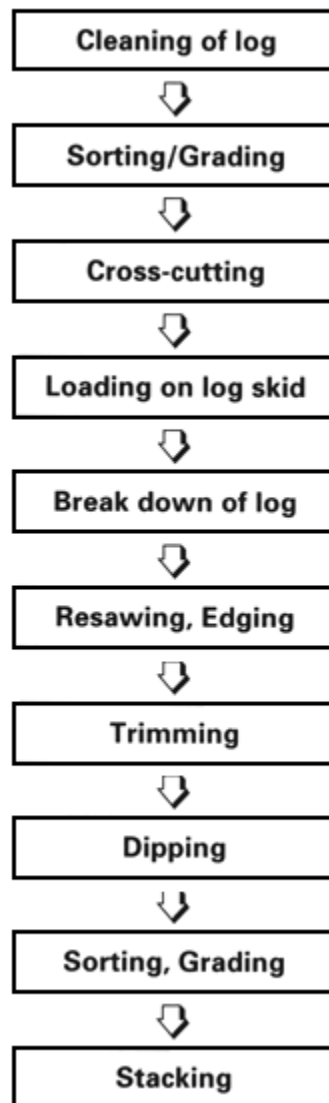

4.1 Sawing patterns

The coconut stem shows a decrease of physical and mechanical properties from periphery to pith over each cross-section. This property distribution requires an early separation of boards originating from the outer, harder part of the stem, and those from the softer core. By experience, frequent turning of the log during sawing yields the highest recovery of dense material, if broken down with circular or band-saws. The cutting patterns proposed are shown in Figures 19-24. Figure 24 depicts sawing patterns applicable when frame-sawing.

Fig. 19: Cutting pattern for coconut logs

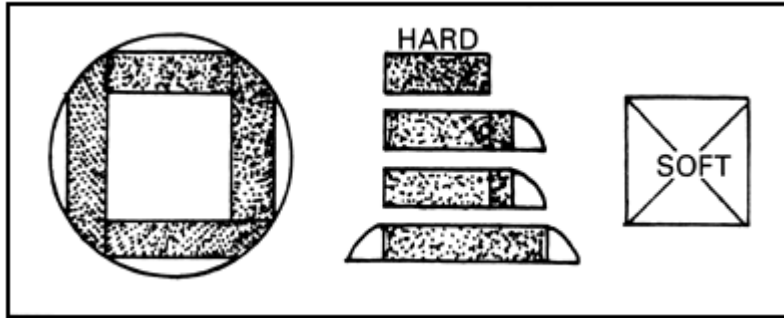

Fig. 20: Additional pattern for cutting purloins

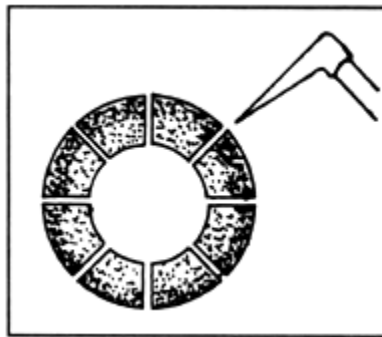

Fig. 21: Cutting pattern for beams

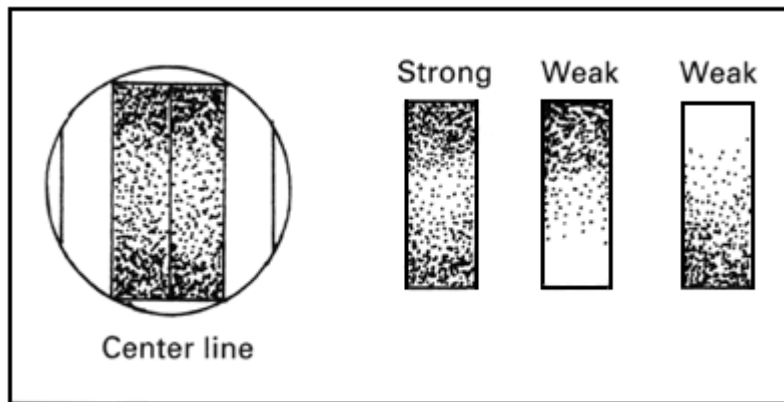
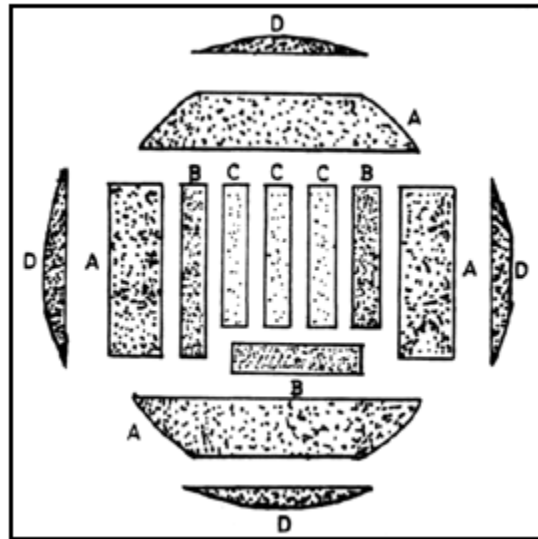
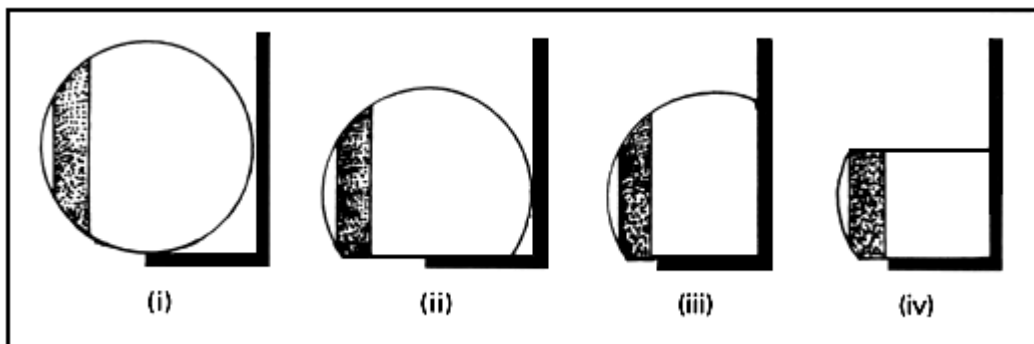

Fig. 22: Cutting pattern relative to selection and grading



Source: FAO, 1985

Fig. 23: Cutting pattern for conventional sawmills



Source: FAO, 1985

Fig. 24: Cutting pattern for frame-sawing

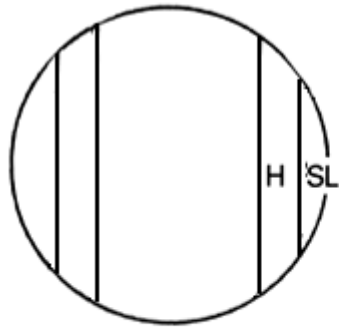

1st. cut



2nd. cut

H = hard
M = medium
S = soft
SL = slab

4.2 Cleaning and ramp-loading of logs

Before loaded onto the ramp, sand and grit must be cleaned from the logs with water and brush, in order to reduce damage or blunting of saws. Depending on the size of the break down saw, the logs may have to be cross-cut again to the required length.

Loading can be done with a forklift, a farm tractor equipped with a frontloader, or manually over a ramp (Photo 28).

Photo 28: Manual ramp-loading of palm logs



4.3 Break down of logs

The logs can be broken down by the following methods:

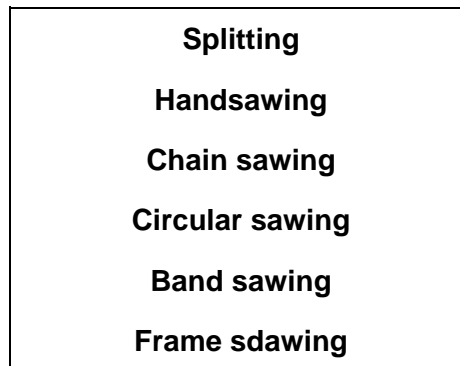

4.3.1 Splitting

The easiest way to breakdown coconut palm logs is to split them with wedges. If this method is applied, the log has to be clamped either on a ramp or with the help of wooden pegs to the ground. A line is then drawn along the stem to mark where it should be split. Along this line, wedges are driven into the stem approximately 50 cm apart. After the log is split, the inner, highly perishable part has to be hewn out with an axe or adze. The split boards are rough. They can be used for rafters or trusses in sheds and simple construction.

Equipment:

- axe
- mallet
- wedges

Advantage:

- low labour input
- low investment for equipment
- less time consuming than handsawing

Disadvantage - only rough material can be recovered

4.3.2 Handsawing with two-man ripsaw

This method has been traditionally applied in many coconut palm growing countries for the ripping of smaller numbers of shorter logs.

Procedure:

- prepare a ramp (Figure 25)
- fix the log (ca. 3 m long) on ramp with nails or wedges
- mark the planned cuts
- execute sawing (Figure 26)

- Equipment:**
- two-man ripsaw (Figure 27)
 - wedges
 - hammer, nails, pliers
 - filing and swaging set
 - ramp
- Advantages:**
- simple technology
 - low investment
 - recovery rate of about 45 %
- Disadvantages:**
- slow and tedious process
 - only shorter lengths can be sawn

Fig. 25: Fixing of coconut log for handsawing

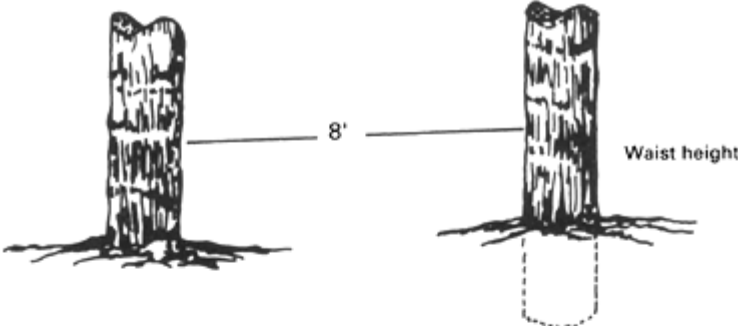

Ramp that holds the coconut trunks while being sawn with a two-man ripsaw.

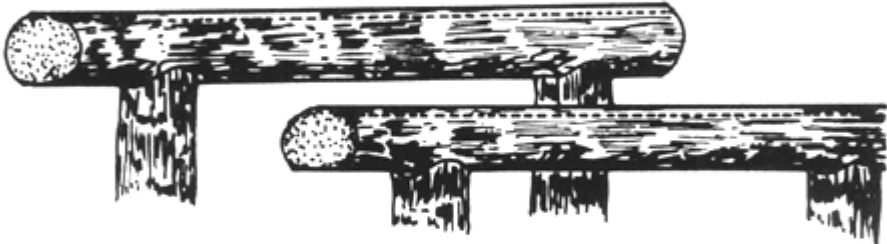

Position of coconut trunks when stabbing two sides.

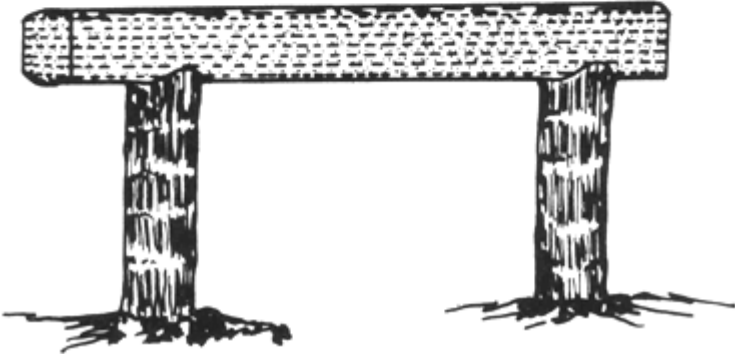

Coconut trunk ready for rip-sawing.

Source: Ouinones et.al., 1983

Fig. 26: Manual sawing of coconut logs

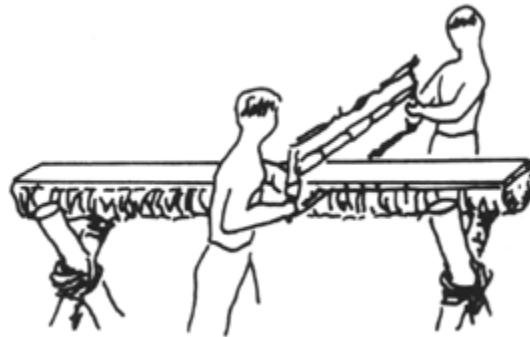

Source: Juson, 1984

Fig. 27: Two-man ripsaw for coconut palm logs

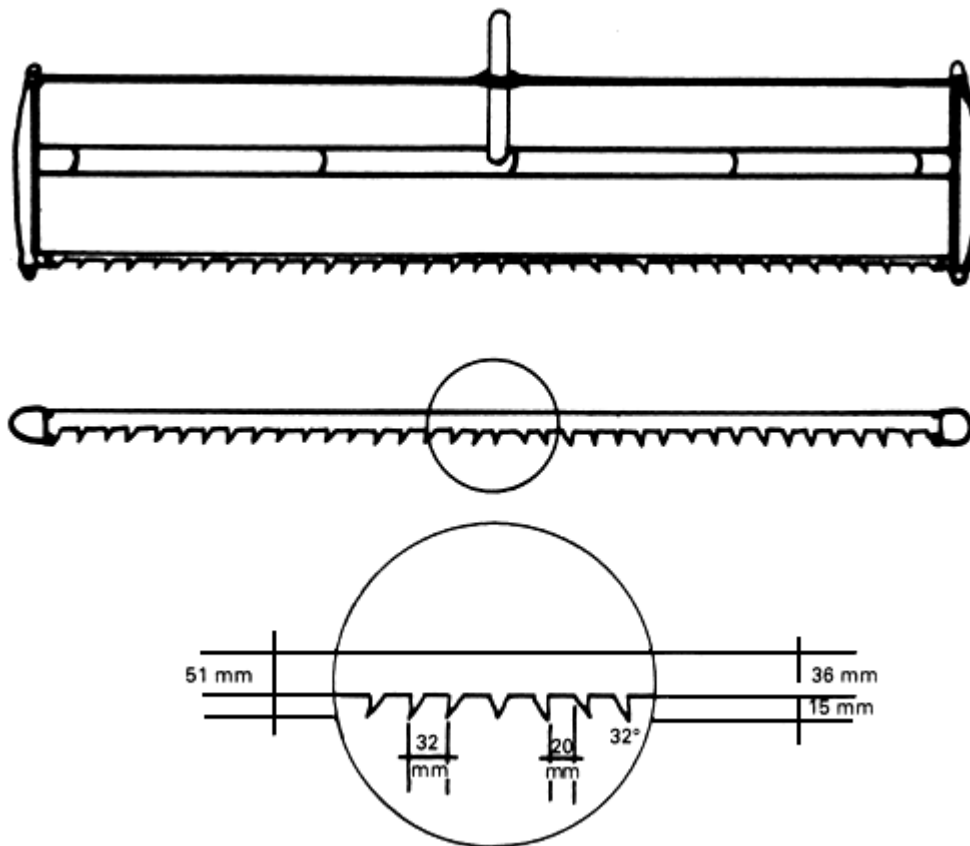

4.3.3 Chain-sawing

Chain-saw ripping (Photos 29, 30) yields a higher production rate than manual sawing. However, as with the latter, it is only applicable where a small number of logs is to be converted. The production rate is about 0.04 m³/ man-hour. A recovery of about 45 % can be achieved.

- Procedure:**
- fix the log on a ramp
 - set the chain-saw and fix the clamping attachment
 - place the clamping device on top of the log, thus having the motor and handle on top of the log and the bar vertical (Figure 28)
 - push the saw through the log while sawing
- Equipment:**
- ramp
 - chain-saw, min. 10 hp
 - bar min. 60 cm, with sprocket nose
 - chipper chain, spare chain
 - filing and repair set
 - clamping attachment (available with chain-saw manufacturers)
- Advantages:**
- low initial costs
 - portability
 - less laborious than manual sawing
 - higher production rate than manual sawing
- Disadvantages:**
- lower production rate than circular or band-sawing
 - frequent resharpening of chain necessary
 - wide saw kerf
 - rough sawing surface

Fig. 28: Sawing coconut logs by chain-saw

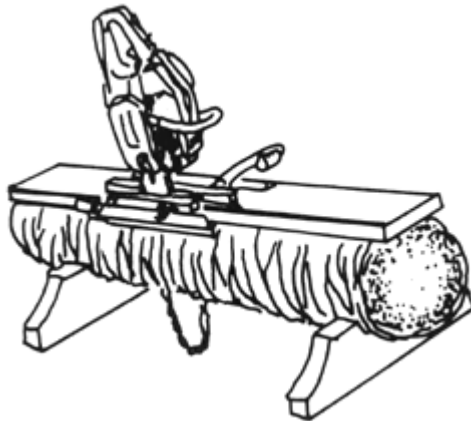

Source: Juson, 19B4

Photo 29: Chain-sawing of palm stems



Photo 30: Chain-sawing of palm stems with guide bar



4.3.4 Circular sawing

Coconut logs have been successfully sawn with circular saws in various countries (Photo 31), and the following recommendations are the result of extensive research work undertaken in Zamboanga. Two alternative set-ups are possible, dependent on volume and area of operation:

- stationary mill
- transportable mill.

In both cases, the set-up is made up of:

- headrig (main saw or breakdown saw)
- breast bench (resaw)
- log skid
- dipping tank.

The saw, whether transportable or stationary, should be roofed (thatch, corrugated iron, or other) to protect the operating staff, timber, and equipment against sun and rain. To reduce stifling heat, the shed should be airy, preferably open on the sides. The log-yard, like the sawmilling area, should be cleared of vegetation, well-drained, and be covered by a layer of gravel or compacted material, which prevents the build-up of mud during rainy seasons. The dipping tank is essential to provide temporary protection of sawn timber against fungi and insects for the duration of seasoning. It can be made of old oil-drums cut in half lengthwise and welded together, or a trough dug into the soil and lined with plastic, or a plastic-lined wooden trough. Stationary mills might be equipped with a concrete trough. The dipping tank has to be protected by a roof to prevent the dilution of the preservative by rainwater.

Photo 31: Circular saw headrig (note the wide gullets in saw-blade)



Procedure:

The logs are loaded from the log-yard to the log skid. In order to facilitate later grading, only one category of logs (butt logs, middle logs or top logs) may be loaded and sawn at a given time. The logs should preferably be green in order to facilitate sawing. Prior to sawing operations, the saw has to be properly aligned, the saw-blade hammered, and the teeth sharpened (Astell,1981). The saws should either be tungsten-carbide (TC) tipped or equipped with stellite inserted teeth. The saw guides have to be properly set. They can be made of hardwood, even hard coconut wood. Watering of the saw-blade during sawing has proved helpful in order to reduce the heating of the blade due to friction, and to reduce the clogging of sawdust in the gullets.

The logs are cut according to the sawing pattern chosen. The slabs are sorted out for production of small items such as tool handles, novelty items etc., or for firewood or charcoal. The boards are passed over to the breast bench for edging. After edging or resawing, they are treated in the dipping tank (Chapter 7). Prior to dipping, it is advisable to brush off the sawdust, which otherwise may prevent proper surface treatment in the dipping tank, and which may also settle there, thus binding the preservative and reducing its effectiveness. After dipping, the boards are sorted according to thickness, size and quality (grading) and stacked in the seasoning shed.

Equipment:

The choice of equipment depends on the size of the operation. In Table 5 two examples are given. The feed speed depends on the thickness of the boards and the revolutions per minute (rpm). With these set-ups the daily production (1 shift of 6 effective working hours) can be achieved as given in Table 6. These are average figures based on ca. 80-year-old palms of the San Ramon Tall variety in Zamboanga. The recovery depends very much on height and diameter of the palms, on sweep, number and depth of harvesting steps.

Table 5: Data on circular sawmill for coconut wood conversion

Saw type		Teeth	Saw blade	Saw gauge	Rpm	Feed speed
	(hp)	Type no.	Dia (mm)	(mm-BWG)	min ⁻¹	m/min
Stationary mill						
Headrig	100	TC*23	1370	5,18-6	770	15-20
Breastbench	75	TC 48	910	4,19-8	1220	30-45
Transportable mill						
Headrig	100	ins** 19	1120	4,19-8	680	10- 15
Breastbench	100***	ins 13	760	3,18-9	1200	25-35

* Tungsten Carbide tipped

** Inserted teeth

*** Both saws driven by same motor

Table 6: Daily recovery rate from circular sawmills

		Out put	Input	average
	No. logs	m3	m3	%
Stationary mill	50-60	17-21	6-7	34
Transportable mill	25	9	3-4	34

4.3.5 Band-sawing

Coconut logs can be sawn in conventional band-saw mills (Photo 32). All band-saw blades should be stellite. Due to their bending over the wheels, they can not be TC-tipped. The feed speeds to be applied in breaking down the logs range from 10-25 m/min; for edging or resawing feed speeds of 20-40 m/min can be applied. Recovery in band-saw milling has proved to be the highest with up to 50 %.

Photo 32: Band-saw



4.3.6 Frame-sawing

Frame-or gang-saws consist of a frame which carries a number of parallel blades, which can be preset at varying distances. The blades have a heavier gauge than band-saw blades, but they are considerably thinner than those of circular saws. Since they are used straight, their teeth can be TC-tipped. Frame-saws have been developed to breakdown small-diameter logs. The frame moves up and down while the log is pushed through, and the entire log is converted to planks in one go (Photos 33 - 35). Coconut palm logs are broken down in two steps (Figure 24 above).

Photo 33: Frame-saw (infeed)



Photo 34: Frame-saw (outfeed)



Photo 35: Frame-saw blade



4.3.7 Comparison of different saws

The different saws are compared in Tables 7 and 8.

Table 7: Technical data of different saws











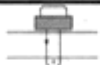

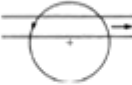
Breakdown of logs sawing machines	Principle	Feed speed m/min	Output m ³ /h 1 Headrig	Output 1 Headrig 1 Resaw m ³ /h	Yield %	Remarks
1. Chain-saw			0,1 - 0,2		40 - 45	
2. Circular saw Stationary Transportable		15 - 45	0,5 - 1,5  0,5 - 0,8	2,2 - 2,8  0,9 - 1,2	30 - 48	
3. Band-saw		15 - 50	0,5 - 1,8 stellite  0,25 swaged bl.	2,5 - 3,5 	45 - 50	Surface area per saw-blade: stellite: 50 - 120 m ² swaged: 25 m ²
4. Gang-saw (Frame-saw)		3 - 5 - 10	4 - 6  2 - 3 	Gang-saw + Edger  4 - 6		Curved cutting line possible → yield ↑ 

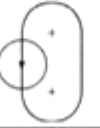
Table 8: Advantages and disadvantages of different saws

Advantage/Disadv.	Circular	Band-saw	
Kerf	wide	small	small
Speed	low	highest	tow
Surface quality	low	better	best
Recovery	medium	high	low
Sawing pattern can be individually	yes	yes	no
Production rate	low	high	highest
Standard of technology	simple	high	medium
Investment costs	low	high	high
Maintenance costs for machinery	low	high	low
Know-how and training	little	much	little
Sawdoctoring skills	high	high	medium
Sawdoctor equipment	high	medium	low
Maintenance costs for	high	medium	low

Important

- Never keep more than several days' log supply in log-yard, since coconut palm stems decay fast!
- Select mill type dependent on size of operation and know-how/expertise available!
- Coconut wood can only be sawn effectively with TC- or Stellite-tipped teeth!
- Always clean logs of sand and mud before sawing!
- Fresh logs are sawn more easily than dry ones!

4.4 Resawing and trimming

Resawing is done with standard resaws, be they circular or band-saws. For the saw-blades and their maintenance see Chapter 4.5. For trimming, the installation of a radial armsaw has proved most useful.

4.5 Cutting steels and saw maintenance

One of the reasons that coconut stems have, as yet, rarely been converted into lumber on a larger scale, is their peculiar texture. In a very soft parenchymatous tissue strands of hard, sclerenchymatous vascular bundles are embedded. While the parenchyma easily gives way and disintegrates into fine particles during sawing, the sclerenchyma cells in the vascular bundles are very hard and abrasive. The sawing of both tissues together results in rapid blunting of conventional saw-blades. Various techniques have been applied to prolong the life of the sawteeth. Results are:

- circular and frame-saw blades should either be
 - tipped with tungsten carbide (TC) or be
 - equipped with stellite, inserted teeth
- band-saw blades should be stellite
- the gullet size has to be increased in order to facilitate the removal of the very fine sawdust during sawing.

The increase of gullet size on a given saw diameter automatically results in the reduction of the number of teeth (for solid tooth nomenclature refer to Figure 29).

Fig. 29: Solid tooth nomenclature

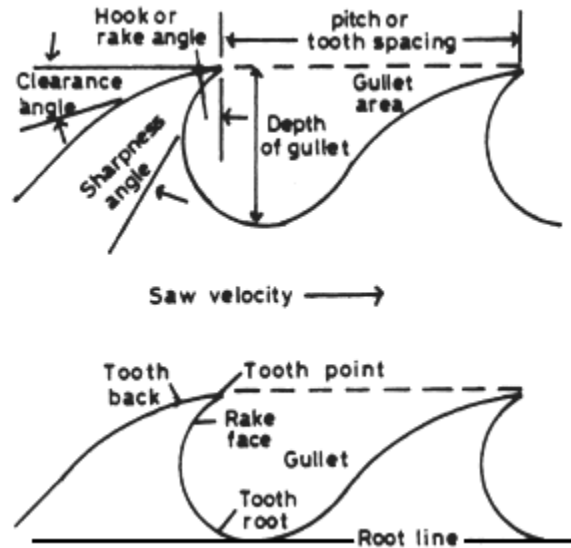

Four different steel types are used for the processing of solid timber, namely:

- mild steel {MS}
- high speed steel (HSS)
- tungsten carbide (TC)
- stellite (ST).

Their advantages, disadvantages and uses are discussed in Table 9.

Table 9: Comparison of cutting steels

	Steel			
	MS	HSS	TC	ST
Advantage	cheap	longer lasting than MS	very wear resistant and longest lasting	Wear resistant
Disadvantage	no wear resistance		Expensive maintenance	
Use	light wood	light wood	dense wood wood based panels	soft wood, dense wood

Tungsten Carbide comes in ready-made, preground bits, which are to be silver-soldered into recesses in the sawteeth. After soldering the bits must be top, face and side-ground. They are available in various qualities. For coconut wood the use of grade ISO K30 is advisable. It is tough and lasts long, but is also brittle. Stones or bullets in the stem, as well as dropping the saw-blade on concrete flooring, may result in breaking of the tips.

For the tooth shape, the following angles have afforded successful sawing with circular saws:

- Hook angle: 20-25^o,
- Top clearance angle: 20^o,
- Sharpness angle: 45 - 50^o (Figure 29).

Attention should be paid to the bite. In order to obtain maximum production before blunting, the bite should be as big as possible. Too large a bite, on the other hand, can cause carbide breakage in the tooth tip. The bite recommended is between 1 and 1.3 mm per tooth.

Stellite is available in rod form and has to be fused under heat on to the base metal of the saw tooth. Three methods can be used for its application (FAO,1985):

- A drop of molten stellite can be applied to the swage cup.
- A large deposit of stellite can be melted on to the end of a saw tooth which has been ground back slightly. The stellite is then formed with dies so that it looks similar to a swaged shaped point.
- Molten stellite can be poured into a ceramic mould around the tooth point. This gives a finished point similar to the second method.

Of these methods, the last is most expensive in terms of initial investment, but saves on the expensive stellite rods. The other two methods, which are more commonly applied, tend to waste a considerable amount of stellite in grinding, since the stellite blob on the tooth point has to be top, face and side-ground (equalized). The stellite grade to be used for coconut wood is Grade 6 (red tipped rod). Cobalide 3 and Eutector 9000 have given good results.

TC- tipped teeth have to be ground with the help of diamond grinding wheels, which are very expensive compared to the conventional silicon carbide types used for stellite and high speed steel. The diamond wheels are available in different grades dependent on the percentage of diamonds.

For proper maintenance of saws an appropriately staffed and equipped saw doctor shop is indispensable. The equipment depends on the type of saws used. The recommended standard equipment is as follows:

- face/top grinder
- side grinder (for band-saw equalizer)
- hammering bench (for band-saw roller-stretcher)
- anvil
- welding set
- soldering set
- tools like hammers, straight edges, gauges
- spare blades
- TC bits or stellite rods
- silver solder.

Photo 36: Band-saw blade grinder

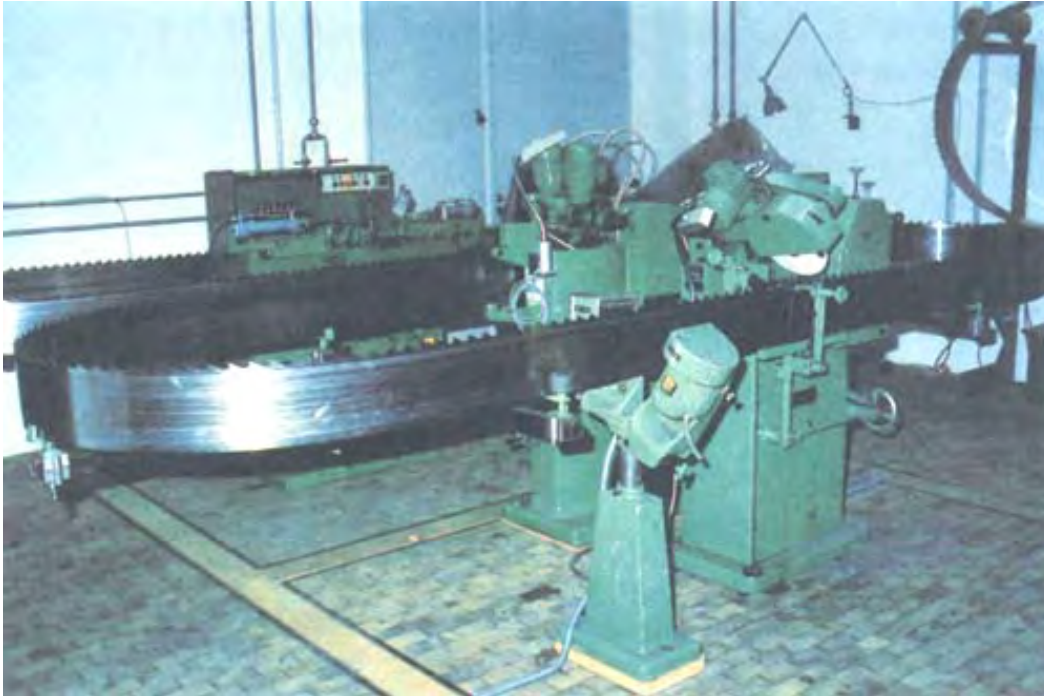

Inserted teeth can be used in smaller operations with transportable circular sawmills. They are available ready-made and can easily be replaced when worn out. They are wear-resistant and need only face grinding. It can be done with a hand-gulleting machine after removal of the saw-blade from the rig, or with a portable "jockey" grinder, which can be clamped on to the saw-blade while on the rig.

Important

- Proper maintenance of saws has a direct influence on:
 - output and thus on economics
 - surface quality!
- Proper training of saw doctors is indispensable!

4.6 Peeling and slicing

Coconut logs can be peeled and sliced. However, due to their anatomical structure the veneer sheets tend to split and break along the vascular bundles, either immediately after peeling, or after drying. Therefore, they can only be used as core veneers.

Thus, peeling and slicing have for the moment no relevance for the industrial use of coconut palm stems.

4.7 Chipping for wood-based panels

The fibrous vascular bundles make good raw material for particle board, gypsum-or cement-bonded panels, or medium-density-fibreboards (MDF). During the process of chipping and hammer-milling the parenchymatic tissue disintegrates into a fine dust. It is preferable to achieve a good segregation of these unwanted fines and the bundles. Segregation techniques are presently developed. The economics of wood-based panels made from coconut timber have yet to be proven.

4.8 Utilization and disposal of waste

During the entire operation of felling and processing of coconut stems, proper waste disposal is of paramount importance in order to prevent the rhinoceros beetle (*Oryctes rhinoceros*) and palm weevil (*Rhynchophorus schach oliv.*) from breeding. Both insects can create havoc in newly established plantations.

From the crown, the edible heart (palmito) can be carved out and used as a vegetable. In larger replanting schemes it might even be considered to can and export this delicious and highly prized palm heart.

The fronds and the discarded top portion of the stem should be burnt in the plantation after drying. In most cases removal and later charcoaling is not economical since the charcoal recovery and its quality are low. Slabs, on the other hand, make good charcoal. If not converted into smaller wooden items, they can be cut into shorter billets and converted to charcoal after drying. The sawdust has to be removed regularly from the saw (Photo 37). With its high starch and sugar content, it is a good substrate for growing edible mushrooms. Laid out in beds under shade, and covered with banana leaves, the padi straw mushroom (*Volvariella* spp.) has been cultivated successfully.

Photo 37: Sawdust accumulation under circular saw



5 Grading

A proper segregation of the sawn coconut timber into different grades is indispensable in order to cope with the demands of different uses. As mentioned earlier, grading starts immediately after felling by deciding on the length of logs to be cross-cut and by marking the position of logs in the stem. For example, only the two bottom logs will provide sufficient high density material. A marking by chain-saw, axe, or spray can on the bottom end is suggested, as shown in Figure 15. After sawing and dipping, the lumber has to be graded and stacked according to size, quality and density group. The techniques applied can be {Schulte,1991, Fruehwald,1992):

- visual grading
- grading by weight (deflection)
- basic density determination
- pilodyn-grading.

5.1 Visual grading

The density groups can be distinguished with some experience by the amount of vascular bundles (dark dots on cross-section) per square unit (Figures 19, 22 and Photo 38):

- High density (HD) = many
- Medium density (MD) = less
- Low density (LD) = small number.

Photo 38: Coconut sawn timber laid out for visual grading



When in round form, visual distinction of the three density groups is easier. This fact could be made use of by the grader already in the log-yard. The different density groups could be marked with distinctly coloured concentric rings before sawing. The boards would bear the mark on their lower end even after sawing and could then be sorted according to their colour/group. However, this is only a rough assessment, especially with longer boards, which may show high density timber at one end and low density timber at the other. Within these density groups, the Zamboanga Research Centre (FAO,1985) suggests the following visual grades:

C-1 (clear one face):

- clear of harvesting step or wane on one face
- harvesting step or wane can appear on up to half of the thickness away from the clear side of the board
- solid spot can appear on the clear face, but in area less than two percent of the face, and individual areas of less than 0.5 cm
- no string spot allowed
- minimum accepted length: one meter.

C-2 (clear both faces):

- clear of harvesting step or wane on both faces
- all sides square
- spot as described in C-1, for both faces
- minimum accepted length: one metre.

Utility:

- wane allowed up to half an edge and half one face
- harvesting step allowed only on one edge all across; but not more than one quarter width of the face; or one face all across but not more than one third of edge
- solid spot allowed in any quantity in medium and high density, and 20 % area of any face in low density
- string spot allowed up to 5 % of the surface area of any face.

5.2 Grading by weight

If placed on two supports, timber tends to deflect by its own weight. The degree of deflection is an indicator for its stiffness, which again reflects upon its mechanical properties. A simple device fitted with a deflection scale or gauge can be installed to grade the lumber (Figures 30, 31). The deflection is given in Table 10.

Fig. 30: Deflection grader for coconut wood

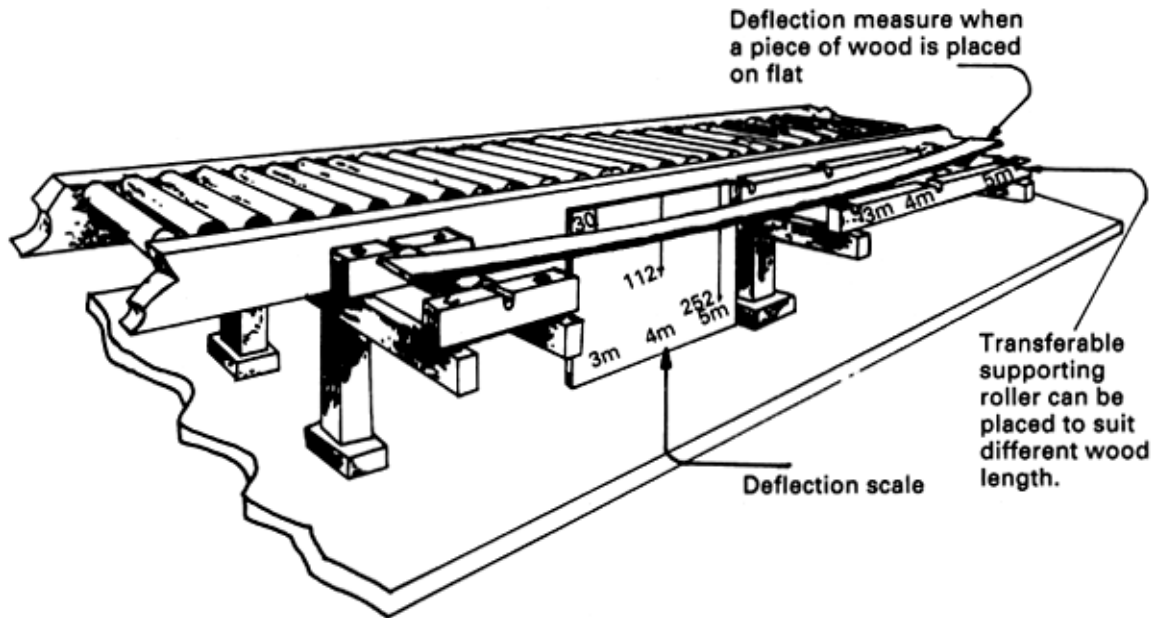

Source Sulc, 1983

Fig. 31: Simple deflection grader

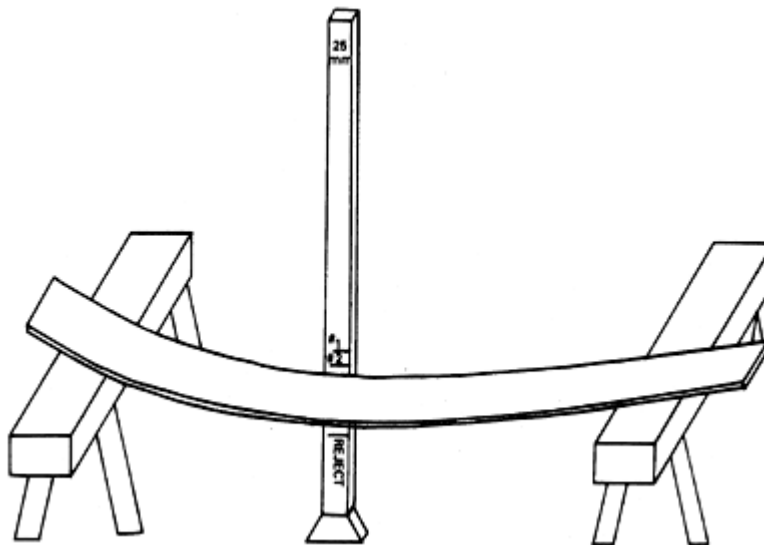

Source: Lockyear, 1983

Table 10: Coconut wood deflection chart

Board length (mm)	Board thickness		Deflection in mm at mid-length of "green" coconut wood		
	(mm) (in)		Grades		
			HD	MD	LD
6000	50	2.0	0-135	136-193	above 193
	38	1.5	0-196	197 -262	above 262
	25	1.0	0-346	347-960	above 960
5500	50	2.0	0- 76	77-109	above 109
	38	1.5	0-111	112-148	above 148
	25	1.0	0-262	263-469	above 469
5000	50	2.0	0- 42	43- 60	above 60
	38	1.5	0- 60	60- 80	above 80
	25	1.0	0-185	186-252	above 252
4500	50	2.0	0- 27	27- 38	above 38
	38	1.5	0- 42	43- 57	above 57
	25	1.0	0-134	13-182	above 182
4000	50	2.0	0- 12	13- 16	above 16
	38	1.5	0- 25	26- 34	above 34
	50	2.0	0- 7	8- 10	above 10
	38	1.5	0- 16	17- 22	above 22
	25	1.0	0- 52	53- 71	above 71
3000	50	2.0	0- 3	3- 4	above 4
	38	1.5	0- 7	23- 30	above 30

Source Sulc, 1983

5.3 Basic density determination

Basic density measurement is the safest method to determine the timber grade. It is based on the close relationship between density and mechanical properties for the lower part of the stem. Basic density is calculated as oven-dry weight of a sample divided by its green volume. The procedure is simple but time-consuming and therefore should only be applied for counter-checks. Density is closely related to hardness. The Janka hardness test measures the pressure required to press a steel ball of 13 mm diameter into a timber sample over the same distance. Tests in Tonga have shown that the hardness of high density material from the periphery of butt logs rates about 10800 newton(N) at 12%moisturecontent,with hardly any difference between radial and tangential sides. European Oak, in comparison, shows only about 5500 N. For its simplicity, the grading system recommended is the deflection rating jointly applied with visual grading as described.

5.4 Pilodyn grading

The Pilodyn-equipment(Schulte, 1991) is a handy tool weighing about 1 kg, which can easily be handcarried into the plantation. It consists of a steel nail which is driven into the wood by releasing a spring with a predetermined energy (6,12 or 18 Joule). Nails of different diameters (2-6 mm) can be inserted into the tool. A scale shows the depth of penetration into the timber. The depth of penetration is closely related to the density of the timber and in turn with its modulus of elasticity (MoE) and modulus of rupture (MoR). The best results were achieved with 6 J-tools and nail diameters of 2.5 mm.

6 Seasoning

For most timber products prior seasoning or wood-drying is essential. It reduces the presence of water in the wood and thus reduces the danger of movement, once the timber is in use. It also reduces the danger of fungal attack and improves the mechanical properties of the wood.

Coconut palm wood has an initial moisture content ranging from 60 % (high density) up to 230 % (low density). In order to reduce the costs of seasoning, it is recommended to air-dry the lumber under roofing at least to fibre saturation point (for coconut wood 24 %) before kiln-drying. Due to its high moisture content and its relatively high sugar and starch content, this material easily attracts fungi, mould and insects during air-seasoning. A dip treatment before stacking (see Chapter 7) is therefore important. There is no significant difference between radial and tangential shrinkage. For HD and MD coconut wood shrinkage is moderate. The LD material, however, tends to develop cell collapse (see also Meier, 1991).

Dry coconut wood needs higher cutting force during processing (see Chapter 8) than fresh material, it also produces more dust. In order to reduce the cutting energy required and to minimize the production of "free" dust, it is therefore advised to execute a II further processing possible prior to drying the coconut wood.

6.1 Moisture content assessment

Moisture content describes the amount of water in the wood at a given time in relationship to the material's dry weight. Water occurs in different forms in wood, i.e. as free water, capillary water and chemically bound water. The moisture content is influenced by various factors, amongst others by the ambient temperature and the relative humidity of the air.

The moisture content wood finally reaches in a given climate is called the equilibrium moisture content (emc).

The purpose of timber drying is to remove the water without defects developing in the wood. "The art of successful seasoning lies in maintaining a balance between the evaporation of water from the surface of timber and the movement of water from the interior of the wood to the surface" (Desch, 1981). In order to achieve this, the moisture content in the wood has to be monitored during the seasoning process. Since wood becomes lighter, once it loses its water content, this monitoring can be done through regular weighing of sample boards. The results are then calculated according to the formulas given in Table 11. The moisture content can also be assessed with the help of a battery-driven moisture meter. The commercial moisture meters are reliable below the fibre saturation point (for coconut palm wood 24 %). The moisture meter is a handy tool and a must in any seasoning operation.

When kiln-drying, the kiln climate can be controlled by help of the Keylwerth-chart (Figure 32).

Fig. 32: Keylwerth-chart for assessment of wood moisture content

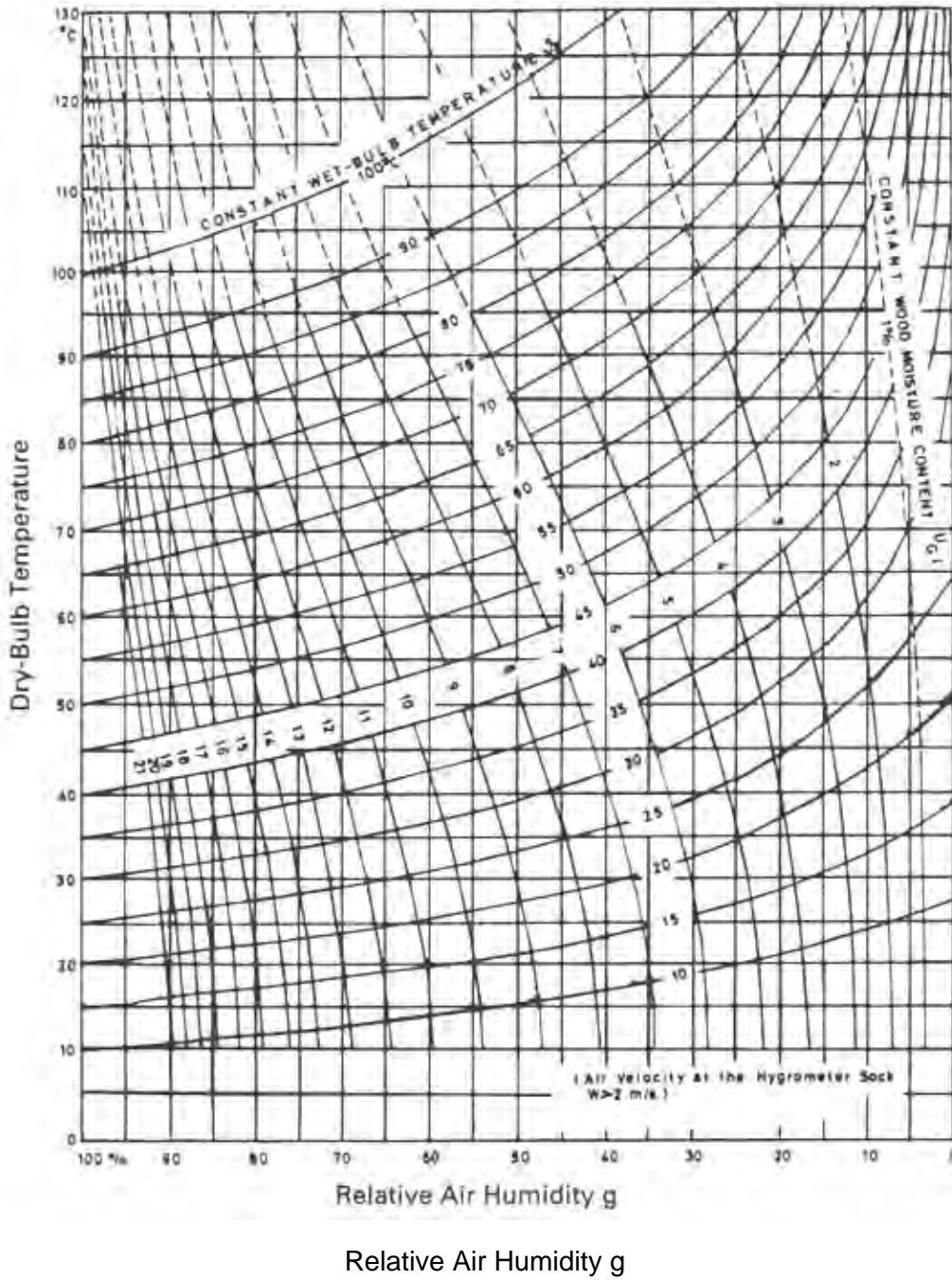

Moisture content equilibrium of timber (according to R. Keylwerth and data from the U.S. Products Laboratory, Madison 1951)

(Example: With a dry-bulb temperature $\vartheta = 45\text{ }^{\circ}\text{C}$ and a relative air humidity $\varphi_L = 55\%$ respectively a wet bulb temperature $\vartheta_f = 36\text{ }^{\circ}\text{C}$ the wood equilibrium moisture content is $\mu_{GL} = 9\%$.)

In order to produce homogenous seasoning results during kiln-drying and to prevent seasoning defects, the batches should always consist of boards belonging to the same density group. During kiln-drying it is recommended to put weight on top of the stack to prevent bow or spring. This can be achieved with clamps and springs which can be manufactured locally (Figure 33).

Fig. 33: Timber stack with pressure clamps

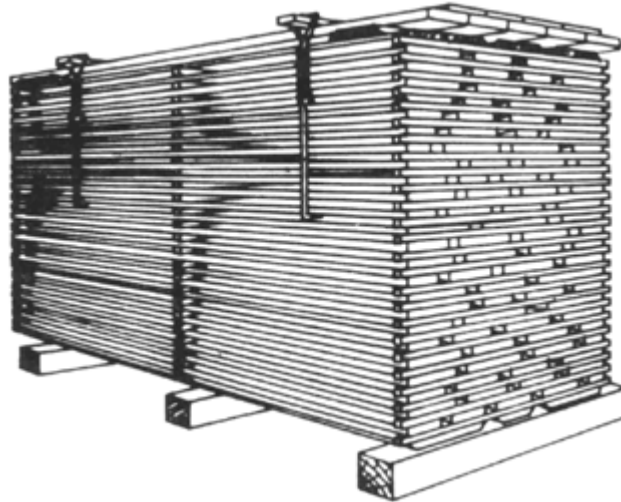

Source: Hildebrand, 1979

Provision has to be made for sample boards in the stack, which are checked for their moisture content first at daily intervals, and during conditioning every two hours. The initial moisture content is assessed by oven-dry method. The later calculation can be done by weighing the test sample and calculating the moisture content back with the following formulas:

Table 11: Formulas for moisture content assessment

<p>Initial moisture content of wood</p> $Mci = \frac{(Ww - Wod) \times 100 (\%)}{Wod}$ <p>Sample moisture content</p> $Smc = \frac{(Wc - 1) \times 100 (\%)}{Wod}$
--

- Mci = initial Moisture content
- Smc = Sample moisture content
- Wc = Weight current
- Wod = Weight oven-dry
- Ww = Weight wet

6.2 Stacking

To allow timber to dry evenly, it has to be stacked properly, irrespective of the drying method applied. Between the stacked layers of boards, stickers have to be placed to allow ventilation of the stack. All stickers should be of the same size (Table 12) and should have been treated before use.

Table 12: Recommended sticker sizes (mm) and distribution

Thickness	Thickness	Width	Distance
up to 30	16	25	400 - 800
31 and above	25	25	600 -1000

The stickers should be arranged in line one above the other in order to distribute the weight evenly. The stacks should be arranged in such a way that the prevailing winds can pass through them (Figures 34 - 37, Photos 39, 40).

Fig. 34: Possible arrangement for drying stacks
(note concrete or stone footing under stack)

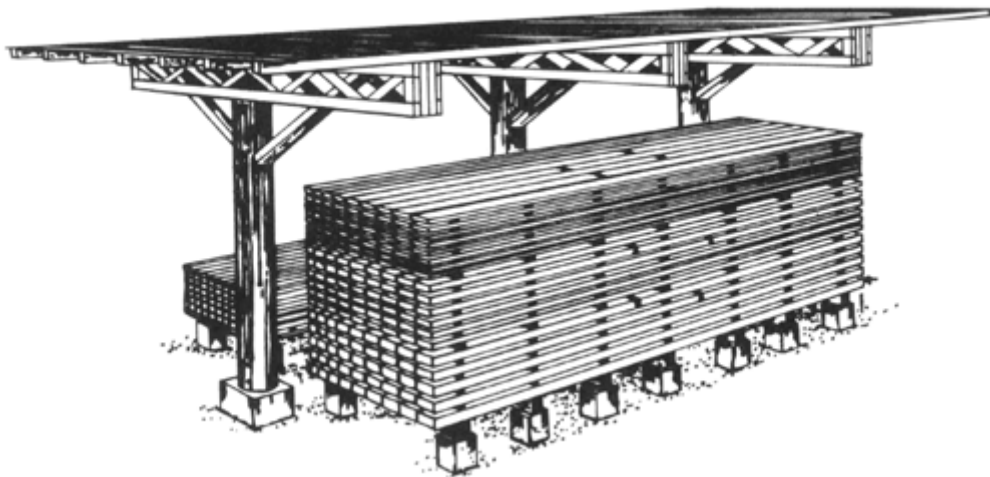

Source: Sulc, 1984, 1

Fig. 35: Foundation of stack with coconut round wood, squared on two sides

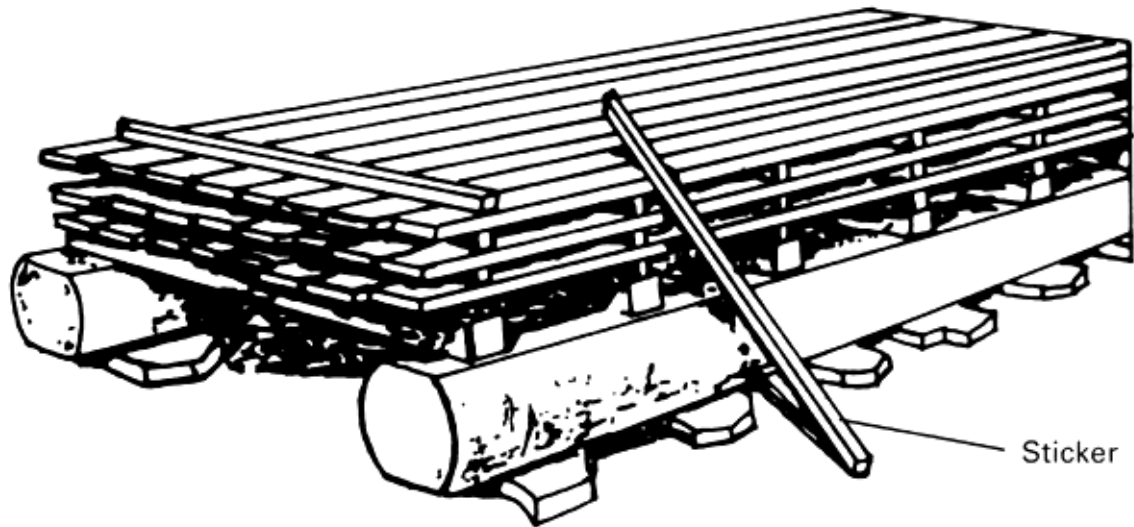

Source: Sulc, 1984, 1

Fig. 36: Stacking of short pieces of wood

Self-crossing soft squares recovered from the center of round wood. Note large spacing for air flow.

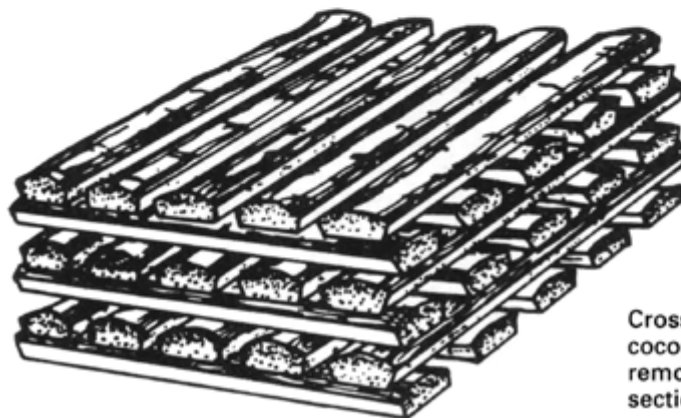
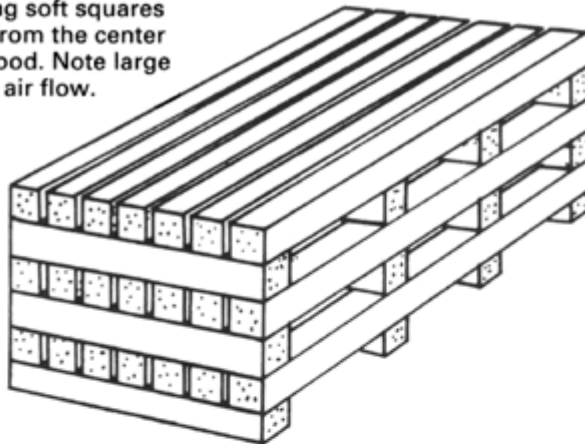

Crossing pile of air drying coconut palm wood. Note removed bark and soft section.

Source: Sulc, 1984, 1

Fig. 37: Timber stacking - in pile

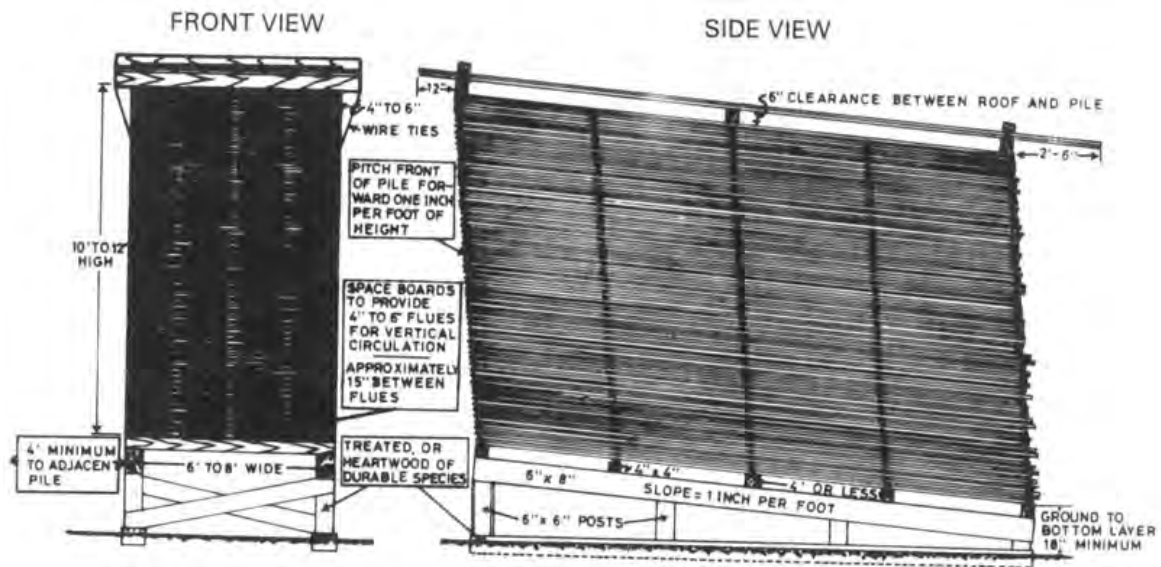

For items requiring slower drying, modifications to minimize checking.

Essential features in piling for rapid and uniform air seasoning.

1. Decrease height of foundation.
2. Decrease spacing between piles.
3. Decrease width of flues.
4. Increase width of pile.
5. Use thinner stickers.
6. Avoid the use of stock for stickers (narrow, dry, special stickers are less conductive to checking).

Source: USDA, Lake States Aspen Report No. 5

6.3 Drying

6.3.1 Air-drying

Air-drying is the most economical, however the most time consuming way of seasoning lumber. To achieve good results, it is important, to:

- stack it off the ground
- prevent stagnant water in the stack
- apply stickers between boards
- stack it in an airy place
- protect the stack against direct sun radiation and rain.

Photo 39: Stacked coconut boards (note fungus-infected board, second from right)



Photo 40: Coconut sawn timber stacks in the open (uncovered)



The best protection is an open-sided shed (Photo 41). The ground should be free of vegetation, preferably of concrete, stones or gravel. The stack should sit on concrete pillars (Figure 34).

Experiences on air-drying coconut sawn timber to equilibrium moisture content (in coconut palm growing areas 17 - 20 %) are given in Table 13.

Photo 41: Sawn timber sheds



Table 13. Air-drying time for coconut sawn timber (to 18 - 19 %) in weeks

Board thickness (mm)	25		50	
Basic density (g/cm ³)	>0.6	<0.6	>0.6	
Kalimantan (Indonesia)	9- 10		>16	
Mindanao (Philippines)	9-10			<24
Luzon (Philippines)	8-11	11 - 13	13-16	
Fiji	8-11			<26

6.3.2 Kiln-drying

Kiln-drying is the term for seasoning of lumber in closed, well insulated chambers or kilns. Different kiln seasoning methods are distinguished, namely Solar-drying, Convection-drying, Condensation-drying and Vacuum-drying. Many combinations and variations of the methods mentioned are commercially available.

6.3.2.1 Solar-drying

Solar-drying makes use of the solar energy. Two types of solar dryers are distinguished:

- the glasshouse type and
- the collector type.

The **glasshouse type** (Figure 38) solar dryer is a chamber with glass-or plastic walls and/or roof. The sunrays heat up the air in the kiln directly. Disadvantages are the fragility of the glazed surfaces and, in case of plastic materials, its limited life time due to the high UV radiation in the tropics.

Fig. 38: Solar dryer - glasshouse type

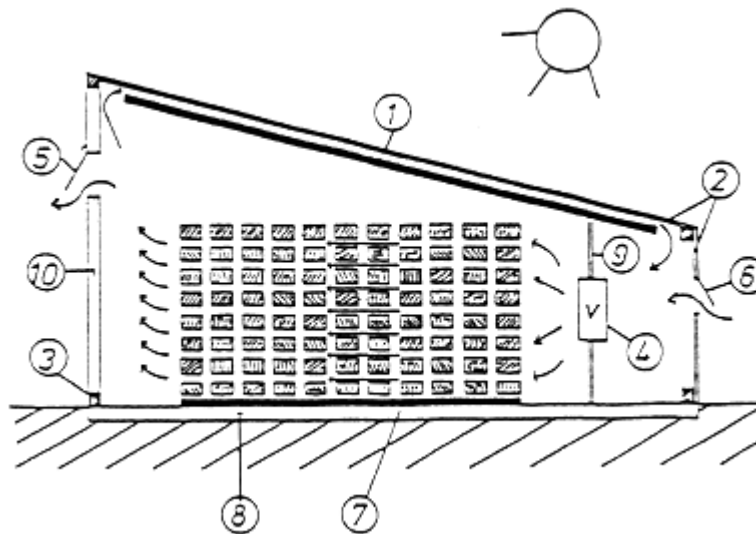

- 1 - heat absorption area
- 2 - transparent walls
- 3 - frame
- 4 - fan
- 5 - ventilation opening (out)
- 6 - ventilation opening (in)
- 7 - timber stack
- 8 - foundation
- 9 - separation wall
- 10 - shade wall, usually well insulated

Due to its construction and the materials used (glass or plastic for roof and walls), this kiln type can not be used in typhoon-or hurricane-endangered regions.

The **collector type** (Figure 39) solar dryer consists basically of an insulated chamber and an outside collector, be it installed on the roof or besides the kiln. In the collector air is heated up by sun radiation, either directly, or over water pipes. The collector type has proven to be easier to control and maintain than the glasshouse type. However, its capacity is limited by the size of the collector, which makes it of little use for large scale seasoning operations. An advantage of the solar dryer is its low operation cost.

Fig. 39: Solar dryer - collector type

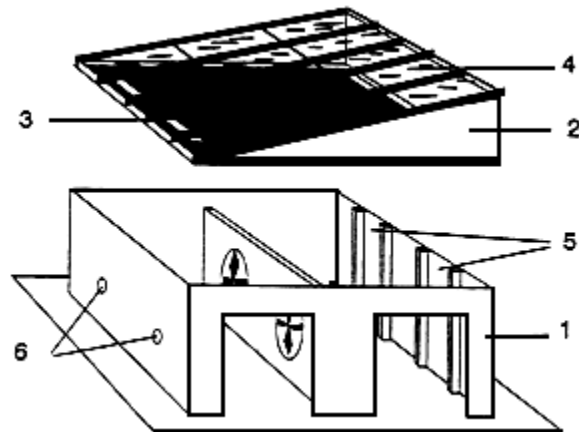

- 1 - insulated wall
- 2 - solar collector
- 3 - dark surface (charcoal) to absorb solar radiation
- 4 - glass cover
- 5 - circular air ducts between collector and seasoning chamber
- 6 - ventilation openings

6.3.2.2 Convection-drying

Convection-drying is the conventional way of seasoning lumber. For this method, the lumber is stacked in a kiln equipped with a heating system and fans. The heated air rises. The fans move the warm air through the stacks. The humidity of the air can be controlled by regulating the temperature, by admitting water vapour through steam sprays, or by changing the air by removal of the saturated air at given intervals through flaps (Figure 40).

Fig. 40: Convection dryer

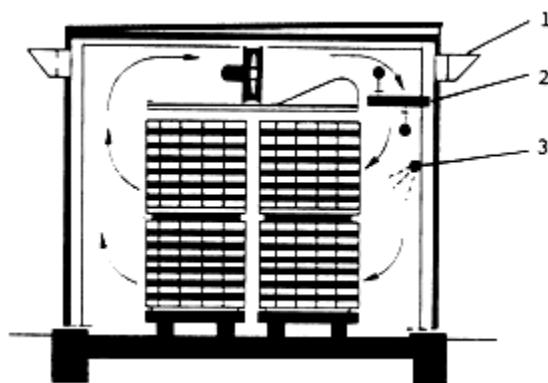

- 1 - ventilation opening
- 2 - heater
- 3 - water spray jet

For convection-drying, the following schedules have been successfully applied in Zamboanga, Philippines. For 50 mm boards of coconut wood with a moisture content above 30 %:

Dry bulb temperature 50° C (122° F) Wet
bulb temperature 40° C (104° F)

This schedule is maintained, until an average moisture content of 30 % is reached Table 14 shows the schedule below 30 % moisture content. Table 15 shows the kiln schedule for drying 25 mm boards from green

Table 14: Kiln atmospheric conditions for 50 mm boards

KO stage	Mhlal av. Mc(%)	Tempetaure		Target av Mc (%)	Appr.tlms hours
		Dry bulbs	Web bulb		
1	30	60° C (140° F)	54°C{130°F}	25	36
2	25	66°C(150°F)	57°C(135°F)	20	52
3	20	66°C(150°F)	54°C(130°F)	12	72
4		71°C(160°F)	70°C(158°F}	14	8
Final conditioning					

Table 15: Kiln atmospheric conditions for boards 25 mm and thinner (from green)

KO stage	Mhlal av. Mc(%)	Tempetaure		Target av Mc (%)	Appr.tlms hours
		Dry bulbs	Web bulb		
1	green	60°C(140°F)	54°C(130°F)	100	up to 60
2	100	60°C(140°F)	51°C(125°F)	60	72
3	60	71°C(160°F)	60°C(140°F)	12	105
4		77° C (170° F)	76°C(168°F)	14	4
Final conditioning					

Source Bnon 1984

Tables 16 and 17 show kiln-drying schedules according to density classes and board thickness.

Table 16: Kiln-drying schedule for pre-air-dried coconut sawn timber, 50 mm, initial moisture content 40 - 50 %

Density group	Timing	Lkkn tempertutre (c)	Umc (%)
HD and MD	entire period	50	9
LD	start	55	12
	end	65	6

Table 17: Kiln-drying schedule for fresh coconut sawn timber, 25 mm

Density group	Timing	Lkkn tempertutre (c)	Umc (%)
HD and MD, wet, mc < 130 %	start	60	12
	end	70	6
LD, mc = 40 - 50%	start	65	12
	end	70	6

6.3.2.3 Condensation-drying

In the condensation dryer (also called dehumidifier - Figure 41) the saturated air is continuously taken up by a condenser. It is cooled below the dew point and the condensed water is led outside the kiln. The energy needed for this process is produced with a thermal pump. The thermal energy provided by the thermal pump warms up the dried air which is then be returned into the air cycle inside the kiln.

Fig. 41: Condensation dryer

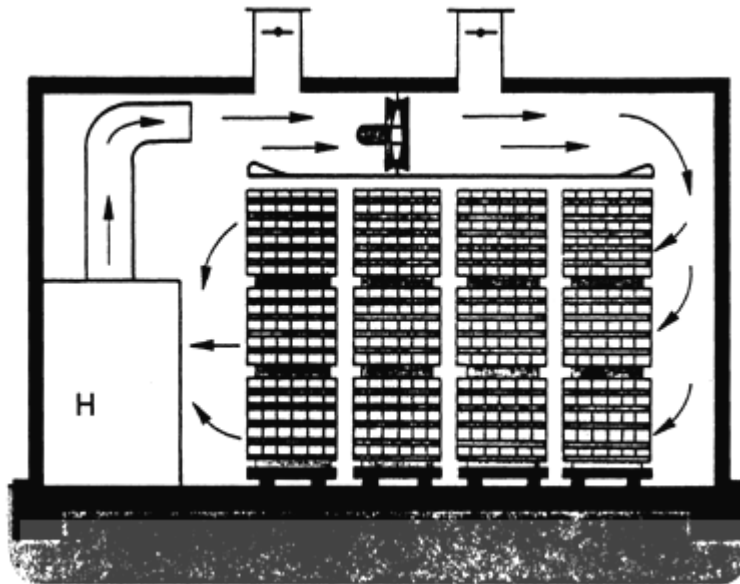

6.3.2.4 Vacuum-drying

This method works on the basis that vacuum reduces the boiling temperature of the water contained in the wood and thus allows its easier and faster evaporation. The vacuum dryer consists basically of a pressure cylinder and a vacuum pump. It is mainly used for small amounts of timbers which are difficult to dry and/or for shorter drying times in comparison to other kiln-drying techniques.

6.3.2.5 Comparison of different drying methods

The advantages and disadvantages of the different drying methods are compared in Table 18.

Table 18: Advantages and disadvantages of drying methods

	Drying time	Investment costs	Operation costs	Maintenance cost*	Skill	Industrial use
Air	long	very low	very low	very low	very low	high
Solar	less long	low	very low	high	low	low
Convection	short	high	high	high	high	high
Condensation	short	higher	high	high	medium	medium
Vacuum	shortest	highest	high	high	high	medium

6.4 Seasoning defects

The dense material shows few seasoning defects, most common are fine surface checks. The low density material, however, is prone to spring, cup, twist, case hardening and cell collapse (honey combing), if not properly seasoned (Figure 42).

Fig. 42: Seasoning defects in coconut wood

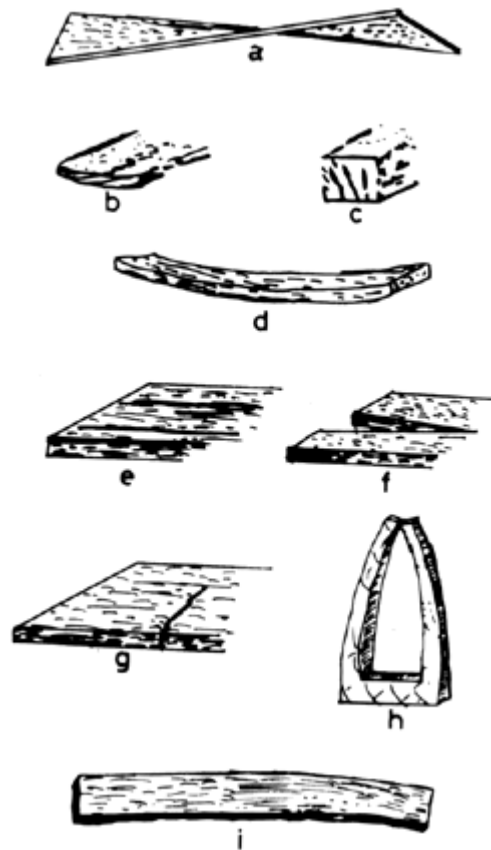

Various defects in timber:
a = twist; b = cupping;
c = honeycomb checks;
d = bowing; e = checks;
f = end split;
g = compression failure;
h = behaviour of test sample from a case-hardened board;
i = spring.

Source Desch, 1982

6.5 Seasoning of poles

Logs designated for later use as power poles have to be debarked to accelerate drying. This can be done manually with simple two-handed knives made from old car springs (Figure 43). After debarking, the future poles should be stacked under roofing and off the ground for drying. The seasoning time required is 4-5 months.

Fig. 43: Debarking of coconut poles



Removing Bark by Debarking Knife

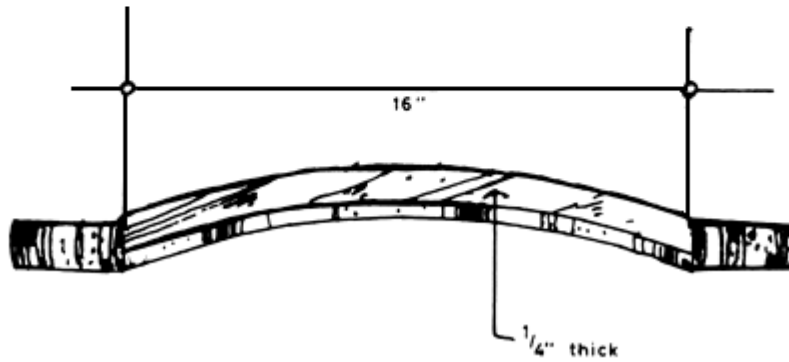

Debarking Knife

Source: PCA, 1977

7 Timber protection

Coconut wood is classified as non-durable. In order to prevent any attack of fungi, mould or insects during drying, a dip treatment previous to stacking is necessary. Timber used in the interior, e.g. for wall-panelling or furniture, should only be treated if it is of low density. In this case a boron treatment against insects is advisable. All timber exposed to weathering conditions as well as timber in ground contact needs an additional long term treatment after seasoning and machining.

7.1 Constructive prevention

In construction and housing, ground contact of timber should be avoided in order to prevent the transfer of moisture or insects from the soil. Equally, direct contact with concrete foundations should be avoided. It is advisable to place a layer of tar-paper between the foundation {bricks, concrete foundation, pillars) and the coconut wood. If on pillars, additional protection against termites can be provided by placing "termite shields" between the wood and the pillar. These are thin pieces of galvanized sheet metal bent at an angle of about 45° downwards (Figure 44).

Fig. 44: Termite shield

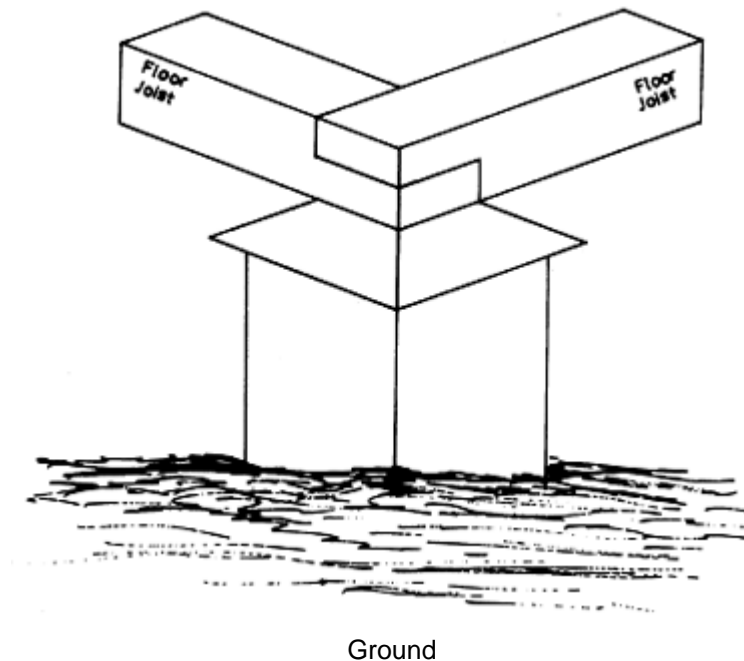

Water pockets create an ideal environment for fungi to develop. The possibility of water pockets developing should therefore be eliminated, especially at window sills, which should have a protruding "dripping edge". No low density timber should be taken for exterior use. For fence posts, which are usually quartered or split, the low density inner part should be carved out with an axe (Figure 45), All round poles should be cut off at an angle on top to facilitate water run-off. The top then has to be sealed or covered by sheet metal to protect the fastest decaying low density pith of the pole.

Fig. 45: Manufacture of coconut fence posts

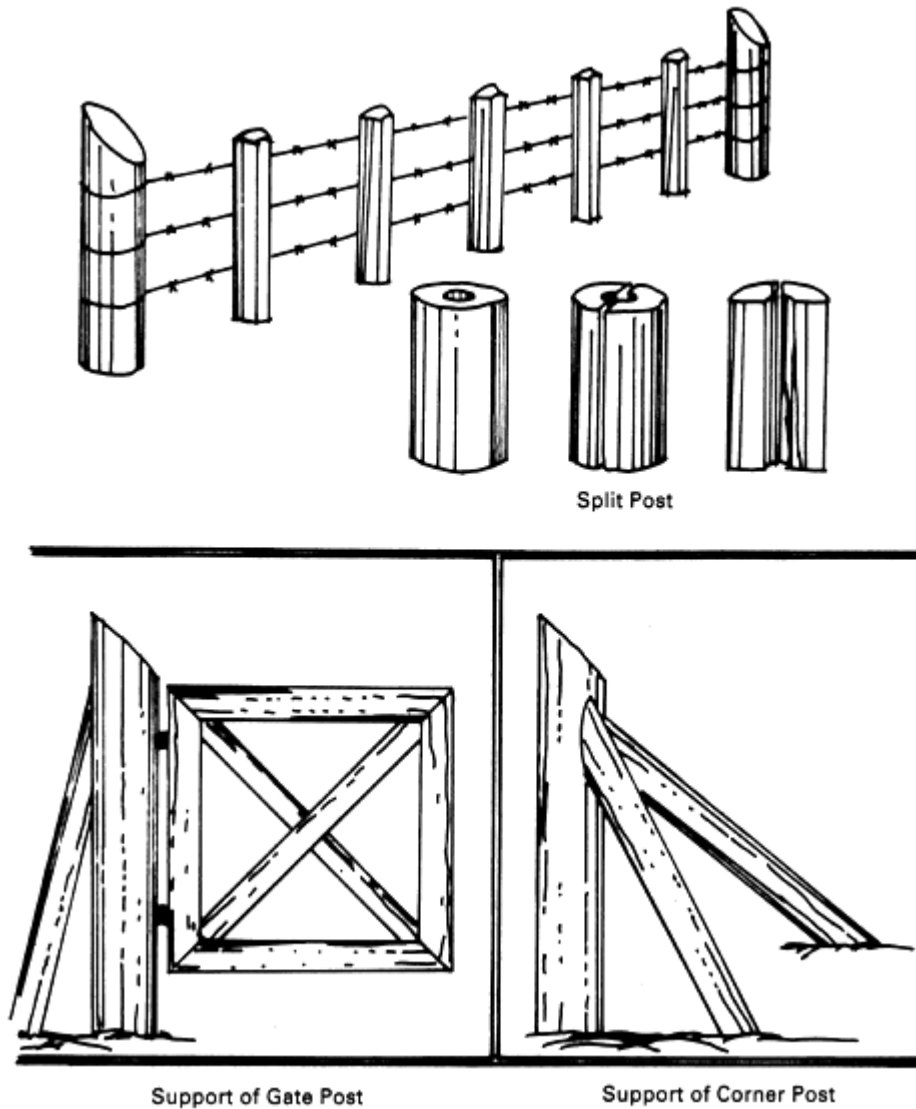

7.2 Wood preservatives

Wood preservatives are chemical compounds used to protect timber against fungi and insects. Dependent on the solvent, we distinguish:

- oil-borne
- water-borne and
- organic solvent-borne preservatives.

The preservatives most commonly applied are (Willeitner and Liese, 1992):

- Creosote
- NAPCP
- CCA
- CCB/CCF
- CC
- AAC
- CU-HDO
- Methylen-bis-Thiocyanate
- Boron
- Borax
- Captafol/Chlorothalanil/Timbafol.

Creosote (coaltar) is an oil-borne derivative of coal, which in the past has been widely applied for preventive treatment of timbers in ground contact or exposed to weather conditions. It protects the timber both against fungal and insect attacks. Creosote gives the timber a blackish colour and exudes a pungent smell, which makes it unwanted for inside use.

NAPCP (Sodium-penta-chloro-phenate) is a water-borne preservative used to prevent fungal growth. It may have side-effects on humans and is therefore banned in a number of countries. Although it is an excellent fungicide, its use is discouraged due to its potential toxicity for man.

CCA (Chromium-Copper-Arsenate) is also water-borne and exists in various formulations with different kinds of chemicals. CCA has been widely and successfully used in the tropics, since it gives an effective and longlasting protection against a wide range of wood destroying organisms including termites. In ground contact the protection is limited, however (Willeitner and Liese, 1992). The retention required is 5 - 12 kg/m³.

CCB/CCF (Chromium-Copper-Boron and Chromium-Copper-Fluorine) are water-borne preservatives in which the arsenic has been replaced by Boron or Fluorine. These salts show less intense fixation and are less effective than CCA (Willeitner and Liese, 1992). The retention required is 5 - 15 kg/m³.

CC (Chromium-Copper) salts are highly effective against soft-rot, but less against brown - and white rot fungi, and insects. The retention required is 10 - 20 kg/m³.

AAC (Alcyl-Ammonium Components), also called Quaternary Ammonium Compounds are organic water-borne preservatives which give only little protection to timber in ground contact. They show hardly any penetration if applied without pressure. The retention required is 5 - 10 kg/m³.

CU-HDO is an expensive new Organic Copper Compound giving good protection against fungi and insects, also in ground contact. No experience exists so far for termites, however (Wiiteitner and Liese, 1992). The recommended retention is 4-20 kg/m³.

Methylen-bis-Thiocyanate (MBT) is a substance effective mainly against blue stain fungi and moulds. It is available as a 5 % solution and should be further dissolved to 1-2 % for use. MBT has a very low toxicity for humans and animals.

Boron is an element giving good protection against some insects, and to a limited extent, against fungi. It is usually applied as salt {Boric Acid, **Borax**} and applied in the diffusion process.

Captafol/Chlorothalanil/Timbafol are water-borne agricultural fungicides.

The preservative successfully used for dip-treatment is a 5% aqueous solution of sodium pentachlorophenate (NAPCP) and 2 % Borax during rainy season or 2.5 % NAPCP and 2 % Borax during dry season. However, due to its high toxicity, it is banned in various countries. Of various alternatives tested a 1% solution based on the active ingredient Methylen-bis-Thiocyanate has proved most successful. Another preservative, although less longlasting in its efficacy, is a Captafol/ Chlorothalanil mixture which has a low toxicity rating for humans. It is available as a compound in powder form (e.g. Timbafol C) and is applied as 4 % aqueous solution. For timber in ground contact, especially power poles and fence posts, creosote can be used. However, it can not be painted over, smells strongly, and on the whole is in many countries more expensive than waterborne preservatives.

Exposed timber should be pressure-treated, preferably with water-borne preservatives. These are usually available in powder form (salt) and are dissolved in water. The most commonly used salt-type preservative in the tropics is copper-chrome-arsenate (CCA), which is very efficient against termites. Some brands are Tanalith C, Boliden K33, and Celcure AP. Other toxic salts are copper-chromium-boron and copper-chromium fluorine. CCA is not advised for roof shingles, where the roof is used as catchment for drinking water.

7.3 Preservation methods

Timber scheduled for treatment should be free of defects. All machining, i.e. borings, recesses etc. have to be carried out before preservation. The timber has to be seasoned in order to achieve adequate penetration of the preservative and its uniform distribution.

7.3.1 Charring

The simplest method applied, which does not require any preservative is the charring of timber. However, it only provides temporary protection. It is particularly applied for cheaper timber in ground contact, e.g. fence posts (Figure 46, 4-7).

Fig. 46: Charring of pole

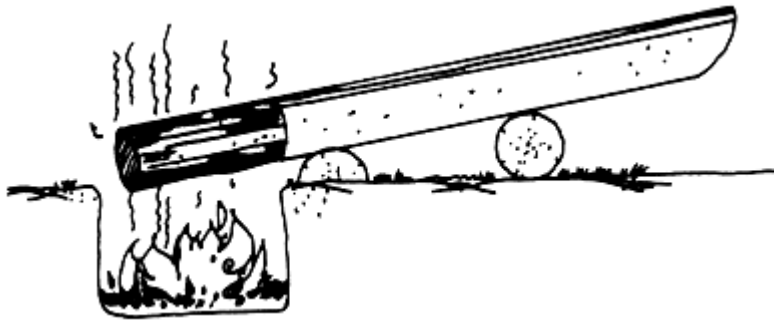

Source: PCA, 1977

Fig. 47: Charring of larger number of poles

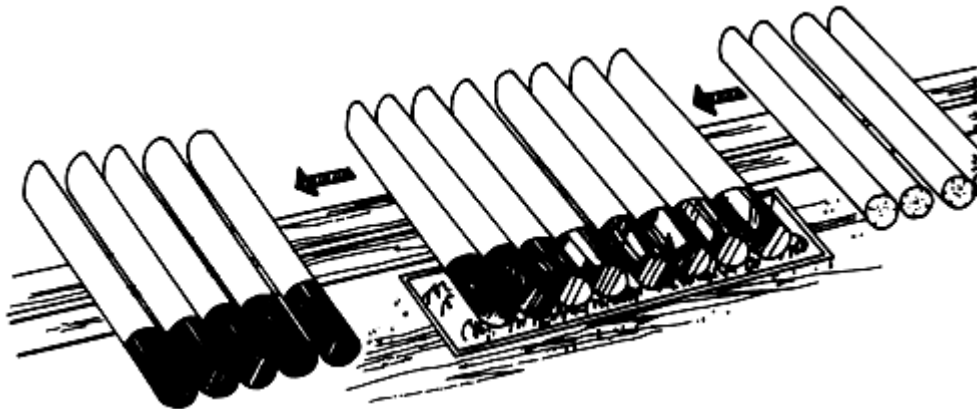

Source: PCA, 1977

7.3.2 Dip treatment

In order to protect the timber during seasoning, the boards have to be dipped in a preservative solution immediately after sawing (Photo 42). The dipping tank can be welded out of half-cut oil drums, or out of a wooden box lined with plastic sheets. The tank should be placed between the resaw and the seasoning sheds to allow an unimpeded workflow. The boards should be free of sawdust and remain in the preservative for at least a minute before being removed and stacked. The solution has to be exchanged at intervals to sustain its toxicity.

Photo 42: Dip treatment of coconut boards



7.3.3 Brushing/spraying

The minimum solution strength of the preservative applied by this method is 3%. Depending on the moisture content of the timber and the roughness of its surface, 1 to 3 coatings have to be applied. However, this method has limited effect only.

7.3.4 Soaking

The timber to be treated can be soaked in a 3 - 5 % solution for up to 8 hours (depending on use and thickness). Soaking provides better protection than brushing or spraying (Figures 48, 49).

Fig. 48: Vessel for soaking

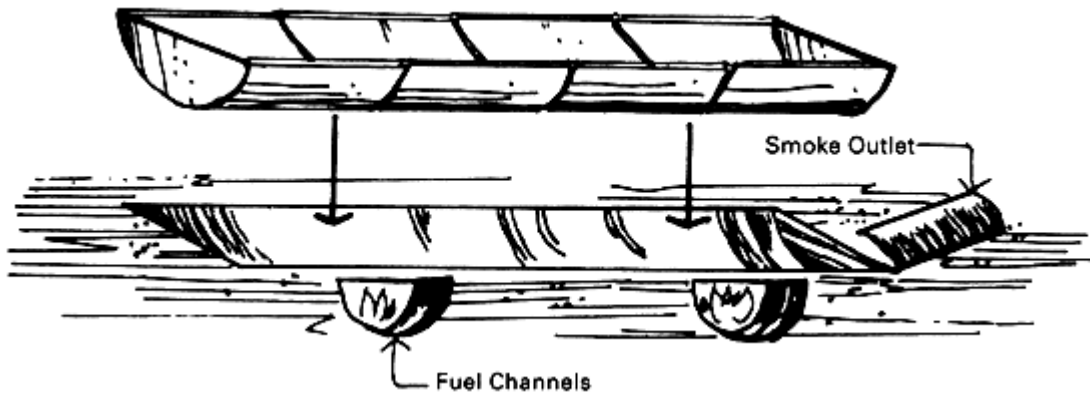
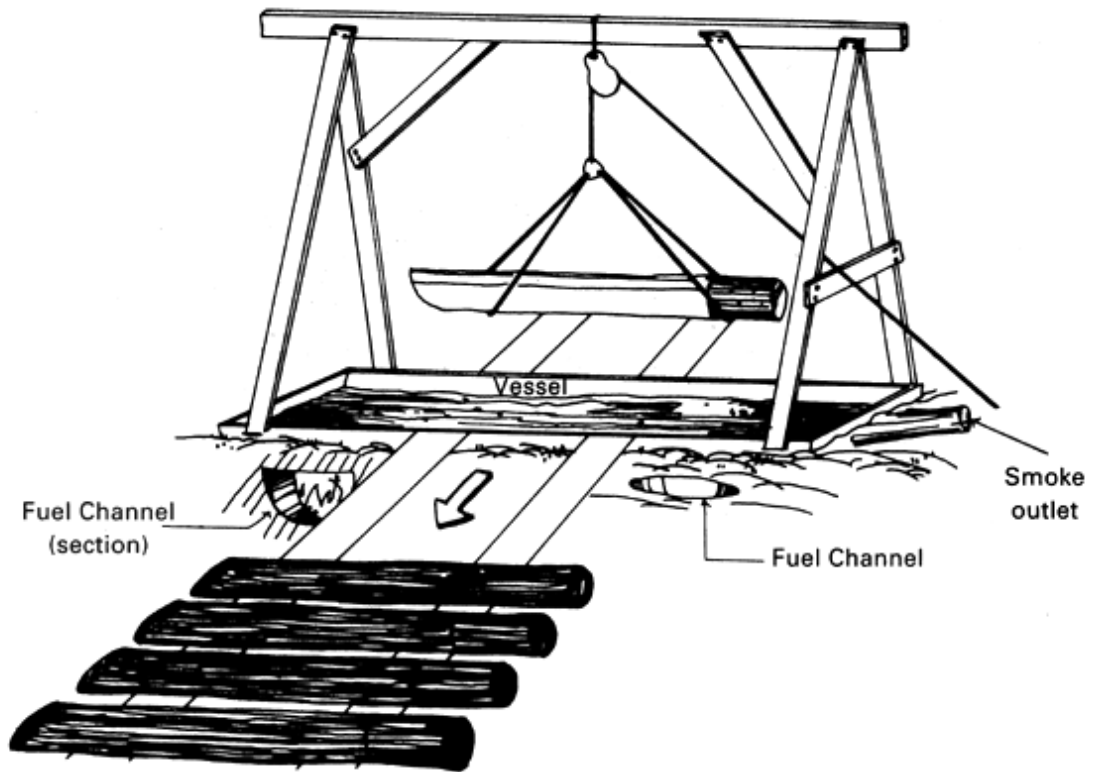

Fig. 49: Soaking of poles in hot preservative



7.3.5 Hot and cold bath

Two open tubs of appropriate length and volume are required to accommodate the timber sizes to be treated. They should be made of stainless steel in order to withstand the corrosive effects of the preservative. One of the tubs should be equipped with a heating source (Figure 50, Photo 43). The timber is submerged in the preservative (e.g. pentachlorophenol in heavy petroleum, or creosote) and heated for 2-3 hours up to 100° C. Then the timber is transferred to the other tub filled with the same preservative but cold. Here it is again kept for 8-24 hours. In both tubs the timber should be totally immersed. During the hot bath, air in the wood expands and is forced out. During the cold bath, the residual air in the wood contracts, thus creating a partial vacuum which allows the preservative to penetrate. Brion (1984) suggests another hot and cold bath treatment, where the hot bath contains boiling water and the cold bath a 3 - 4 % CCA solution (Table 19).

In both cases the timber has to be stacked after treatment under shade with stickers in between for at least 48 hours before use.

Fig. 50: Hot and cold bath for impregnation of power poles

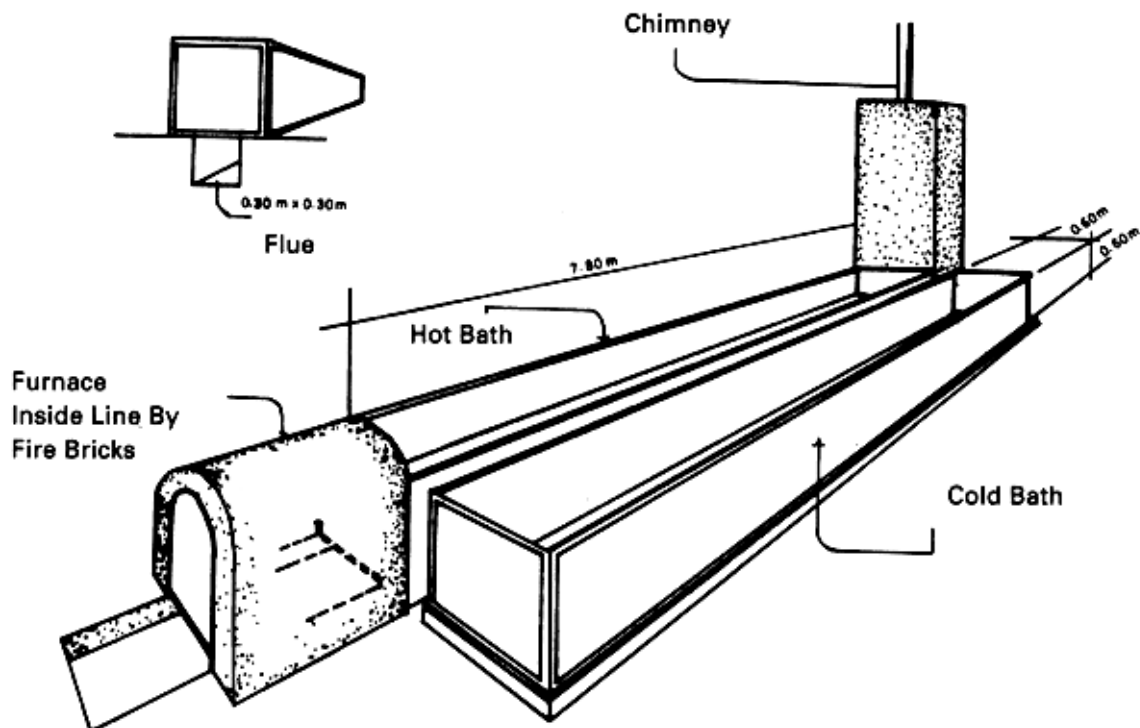

Photo 43: Hot and cold bath



Table 19: Soaking time for hot and cold bath (water/CCA)

Board thickness mm	Soaking time (hours)	
	Hot bath	Cold bath
12	1	8-12
25	2	max. 12
50	to be determined	18
thicker	during process	24

7.3.6 Diffusion processes

Sap displacement method

The simple sap displacement method using caps (Boucherie method) has not proved to be successful with coconut wood. However, patchy to complete penetration was achieved when injecting 10 % CCA solution into the logs at a pressure of 800 kPa (Palomar, 1979).

Simple diffusion process

The sawn timber is dipped into a 20% solution of boron heated up to a temperature of 40° C. The immersion time should last at least 20 minutes. After dipping, the timber is stacked closely and covered with polyethylene sheets in order to avoid evaporation of moisture during storage. The storage time, during which diffusion occurs, should take at least six but preferably 10 weeks. After this period an overall retention of boron of about 3 % of the oven-dry wood weight can be achieved (Palomar, 1986). After diffusion, the treated timber can be used for most purposes in construction. However, it should not be exposed to weathering or used in ground contact in order to avoid hazardous leaching. This method is simple but time consuming.

Double diffusion process

The double diffusion process has given good retention values and is recommended particularly for power poles. It can be applied to green timber, which reduces the processing time as well as the danger of fungal or insect attack during seasoning. However, the poles have to be debarked to allow proper diffusion to take place. The timber is immersed into a hot (80° C) copper sulphate solution for 3 - 6 hours (depending on thickness) and cooled overnight (FAO, 1985). The next day the timber is transferred to a tank containing a cold solution of sodium dichromate and arsenic pentoxide, where the timber is kept for up to two days. Afterwards it is stacked for seasoning in a suitable place (Figure 51).

Fig. 51: Debarked poles stacked for drying

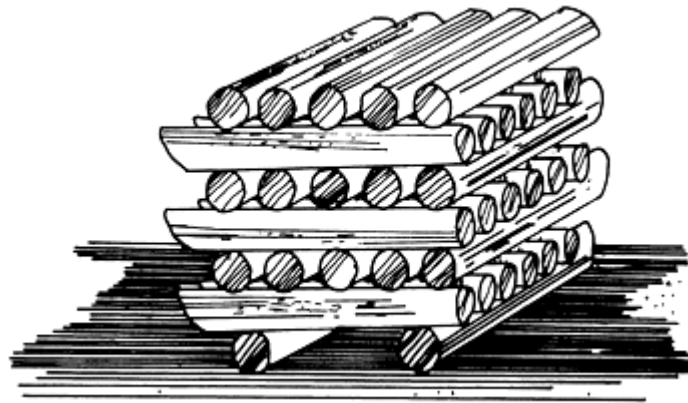

7.3.7 Pressure treatment

The application of pressure to force preservative into the wood in a pressurized cylinder is still the most efficient way of treating timber and obtaining good absorption values. It is done in a commercially supplied pressure plant equipped with pressure cylinder, gauges, storage tank, vacuum and pressure pumps (Photo 44). Various processes have been developed. The most common are the full-cell-process (Bethell), and the empty-cell-process (Rueping). For pressure treatment, the coconut wood has to have a maximum moisture content of 30% (according to Sulc, 1983, the fibre saturation point for coconut wood lies at 24 %).

The following (full-cell-process) schedule has been successfully applied for coconut wood in Zamboanga (Table 20):

Table 20: Preservation schedule

Use	Material	Size mm	Solution %CCA	Initial vacuum -85 Kpa (min)	Pressure vacuum 1400 kPa (min)	Final vacuum -85kPa (min)	Minimum absorption l/m ³
exposed	sawn	25	2	20	45	10	250
exposed	sawn	50	2	20	60	10	250
ground contact	round		6	30	120	10	200

Source- FAO, 1985

- Remark:**
- exposed:
 - to weather, not in ground contact
 - absorption:
 - depends on density, e.g. minimum of 250 litres/m³ for high density timber
 - % CCA:
 - for structural or high value components, 3 - 4 % recommended.

However, it has to be borne in mind that the initial as well as the maintenance costs for such a pressure plant are substantial. For operations on a smaller scale, the hot and cold bath method is therefore recommended.

Caution!!

Most preservatives are toxic

- Prevent skin contact by wearing suitable shoes and gloves when working with preservatives!
- Provide good ventilation in working area!
- Prevent spilling of preservative on the ground!
- Never discharge preservatives into rivers or the sea!

Photo 44: Pressure plant



8 Secondary processing

8.1 Introduction

Secondary processing consists of numerous different processes that may occur a varying number of times in different sequences in the manufacture of the products made from coconut palm wood (see Chapter 2). Here the basic construction material is cut timber having the following characteristics:

- **sorted** according to density, colour, defects, frequency and distribution of vascular bundles, and dimensions
- **dried** to a wood moisture content corresponding to the surrounding atmosphere (point of use) (indoor/outdoor use).

Thus the secondary processing methods include all wood machining methods such as sawing, planing, sanding etc., gluing techniques, and the techniques of surface finishing and assembly. Only the peculiarities that need to be taken into account specifically when processing coconut palm wood will be dealt with below.

Important

Basically coconut palm wood is easier to machine when it is in the wet condition than when it is dry. It is advisable, especially for parts with rather large dimensions, to cut the wood to size and plane it out in the pre-dried state, i.e. with a rather high wood moisture content, and subsequently to dry it to the required final moisture content. The remaining processes can - be carried out after that. Dimensional changes on account of the final drying process must be taken into consideration!

8.2 Processing sequences for various products

The processing sequences are shown below as flow diagrams for five different products/workpieces. The processing sequences and the work operations that they contain can be transferred to a wide variety of comparable products and work-pieces, and illustrate the individual secondary processing methods dealt with in the following chapters. The work operations contained in the processing sequences are mentioned when discussing the individual machining methods.

Important

Quality Control is not distinguished separately in the processing sequences. It is an indispensable part of each work operation!

8.2.1 Frame door with panelling

The principle of the frame door with panelling is used both in furniture doors and in entrance and interior doors of houses. A door of this kind usually consists of:

- vertical side-members
- cross-pieces (rails) and
- panel(s).

Here the joints of the vertical members and cross-pieces have a dowelled design (Figure 52). They are used by way of example as representatives for straight, profiled solid wood components.

Fig. 52: Frame door with panelling

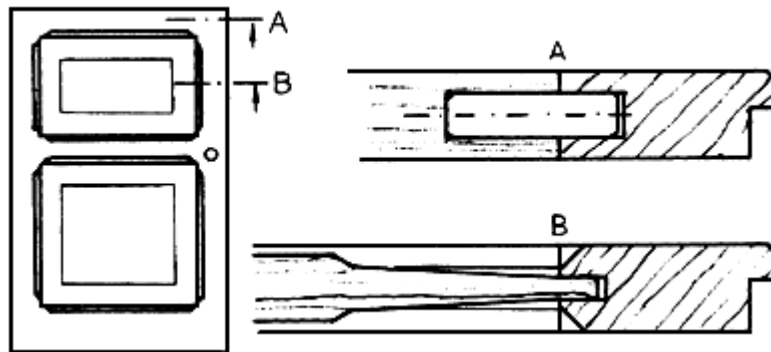

The working sequences for the different parts of the frame door with panelling are given in the following Figures 53, 54 and 55.

Fig. 53: Working sequence for frame components (vertical side-members, rails)

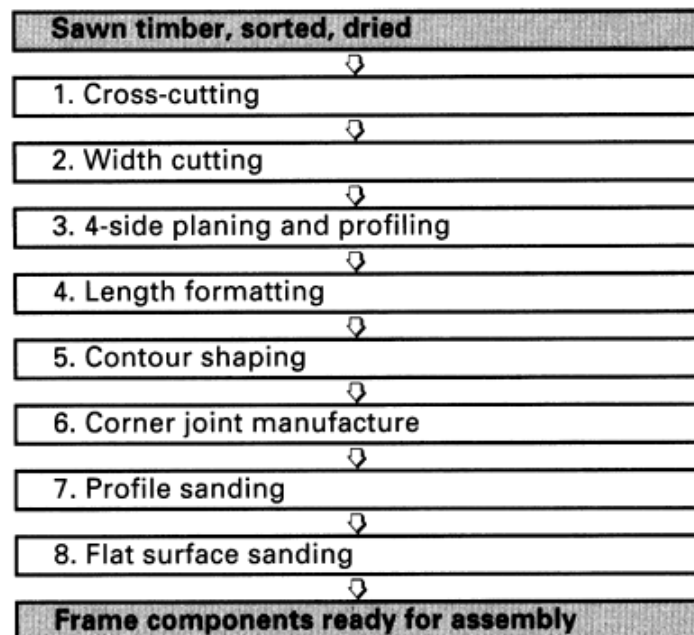

Fig. 54: Working sequence for the solid wood panelling of a frame door

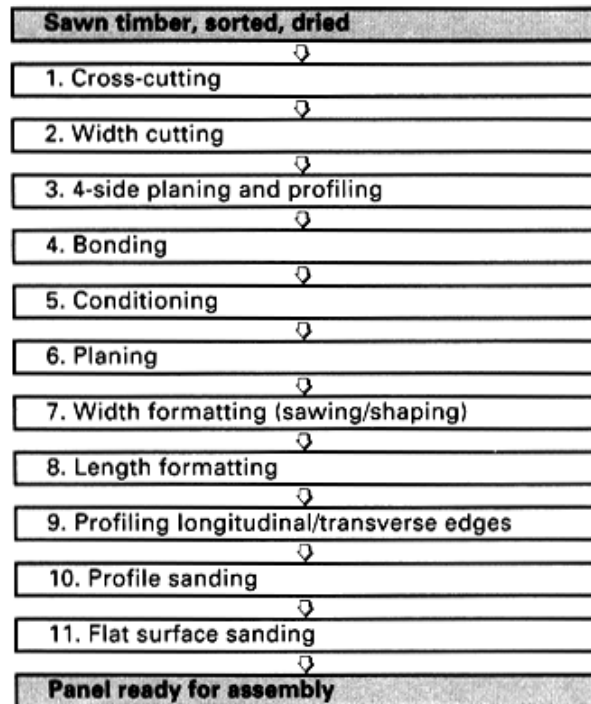
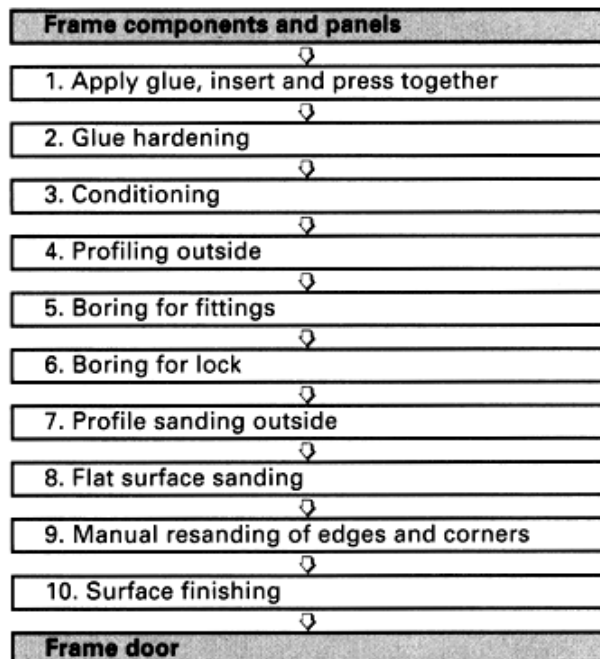

Fig. 55: Working sequence for assembling a frame door



8.2.2 Chair back leg

The chair back leg is a typical example of the working sequence for shaped, profiled components made of solid wood (Figures 56, 57).

Fig. 56: Chair back leg

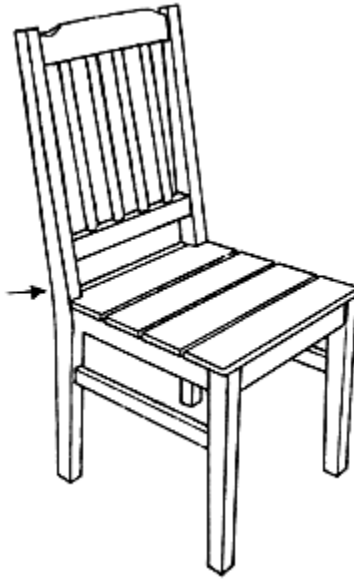
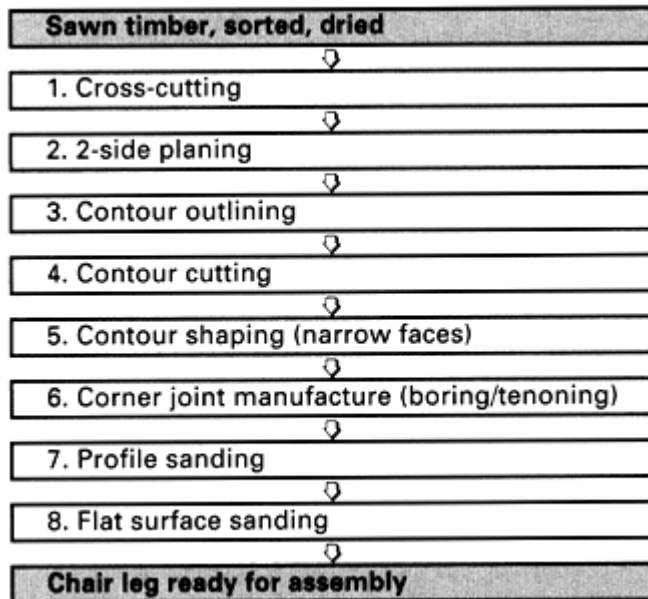

Fig. 57: Working sequence for a chair back leg



8.2.3 Parquet block

The principle of a parquet block is shown in Figure 58 and the working sequence in Figure 59.

Fig. 58: Parquet block

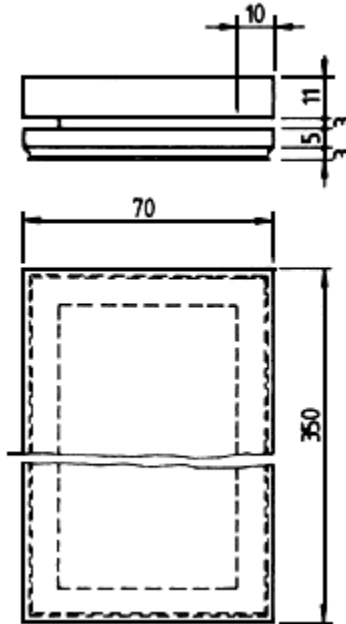
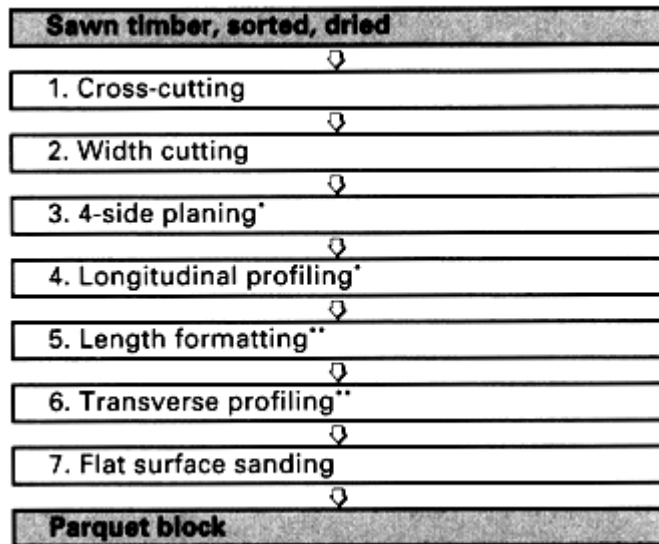

Fig. 59: Working sequence for a parquet block



* = Procedures can be carried out on one machine (moulder).

** = Procedures can be carried out on one machine (double-end tenoner).

8.2.4 Turned components

A turned component is shown in Figure 60 and the working sequence in Figure 61.

Fig. 60: Turned component

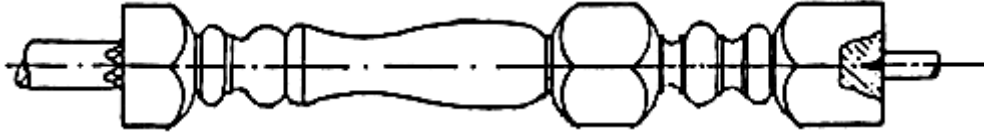
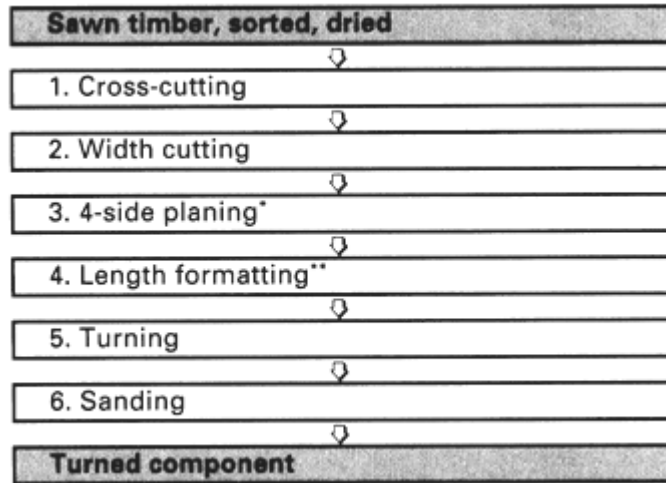

Fig. 61: Working sequence for turned components



* = May be unnecessary

8.2.5 Laminated table-top

A table-top is an example of the work sequence for laminated boards {Figures 62, 63}.

Fig. 62: Table-top

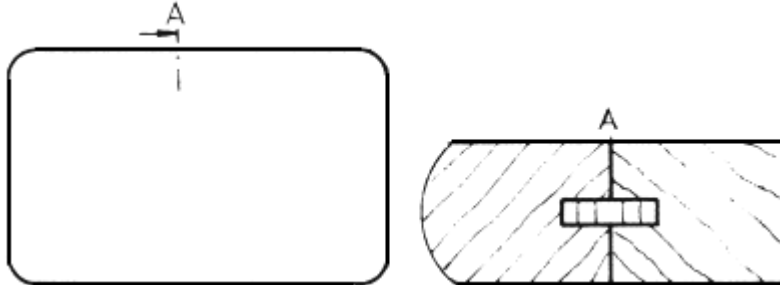
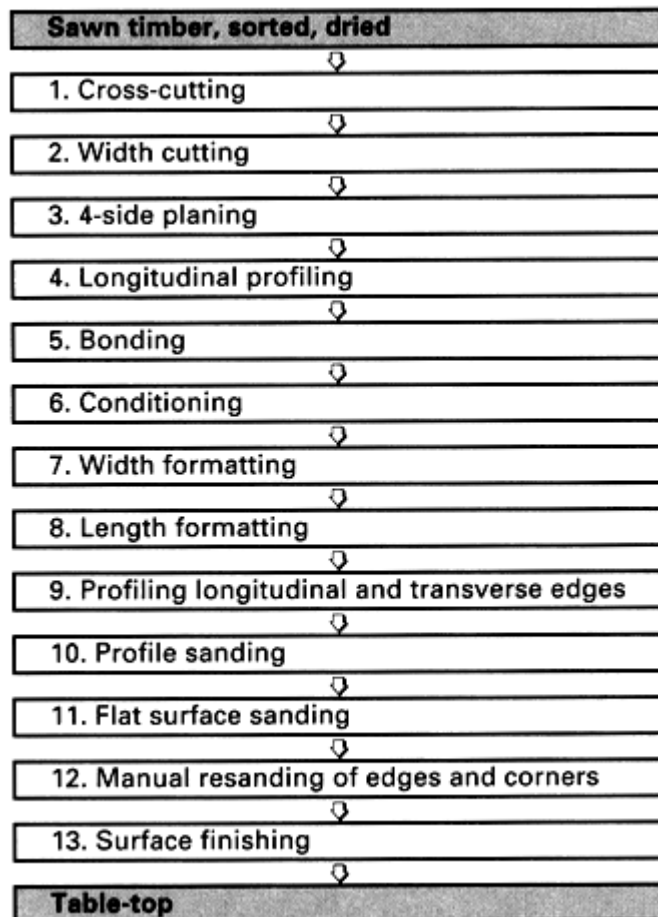

Fig. 63: Working sequence for a laminated table-top



8.3 Effects of the properties of the wood on its machinability by cutting methods

The aim of machining by wedge-shaped tools is to produce a geometrically defined object (workpiece) with a defined surface quality. The production of the object geometry does not constitute a problem if appropriate tooling is used. With inhomogeneous materials like wood, the surface is a complex structure that depends on numerous parameters affecting it (see Figure 64).

Fig. 64: Effects on surface quality

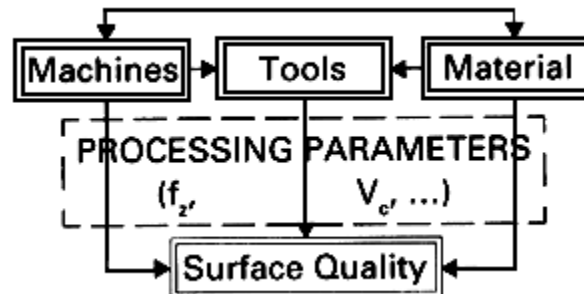

The parameters that have an effect are also inter-dependent. For example a required surface quality cannot be guaranteed solely based on the setting of certain machine data. Important factors affecting machinability are dealt with under the headings 8.3 to 8.5.

When defining surface quality, a fundamental distinction is made based on the intended use:

- ready for building; rough-sawn surfaces, adequate normally for building components
- ready-planed; surfaces planed
- ready for glue-bonding; planed surface, e.g. suitable for laminating
- ready for surface finishing; as a rule a sanded surface suitable for application of surface finishing materials.

Wood characteristics

As already mentioned in Chapter 1.2, coconut palm wood constitutes a parenchymatic ground tissue in which vascular fibre bundles are embedded. Each vascular bundle consists of phloem, xylem and parenchyma cells surrounded by sclerenchyma cells containing silica. This anatomy, which is distinct from all other species of wood, has particular results depending on the direction in which the fibre is cut during machining.

1. Cutting along grain or with grain (Figure 65)

Uses: e.g. planing, shaping

The lesser intrinsic strength of the parenchyma causes the latter to tear out more easily and to become visible as "raised grain" in the surface and/or along the edge.

Fig. 65: Cutting along grain or with grain

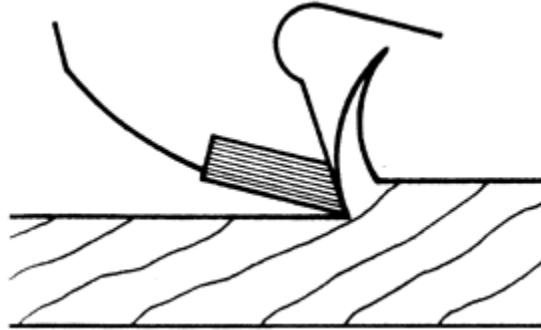

2. Cutting against grain (Figure 66)

Uses: e.g. planing, shaping

Part of the fibres and especially the vascular bundles cannot be cut off but are "torn out" and cause backward splintering on the surface and at the edges.

Fig. 66: Cutting against grain

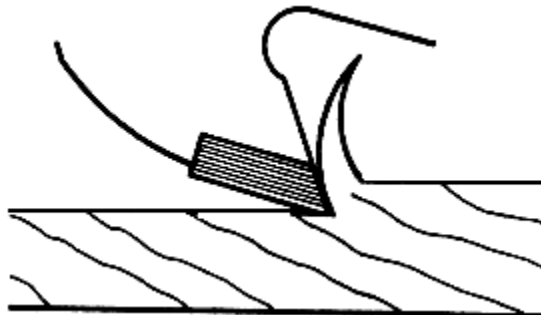

3. Cross-cutting at right-angles to the grain (Figure 67)

Use: e.g. sawing

The lesser intrinsic strength of the parenchyma may cause the latter to break out more easily and to become visible as "raised grain" at the tool entry edge and at the tool exit edge.

Fig. 67: Cross-cutting at right-angles to the grain

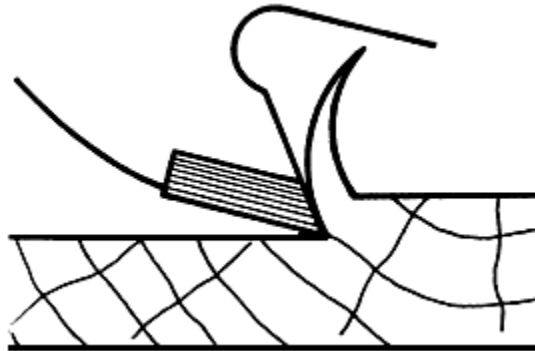

4. Cutting in end grain (Figure 68)

Use: e.g. tenoning and mortising

In spite of the use of counter-stops, the parenchyma may break out at the tool exit edge. In addition the fibre ends may not be cut off flush and may project above the surface.

Fig. 68: Cutting in end grain

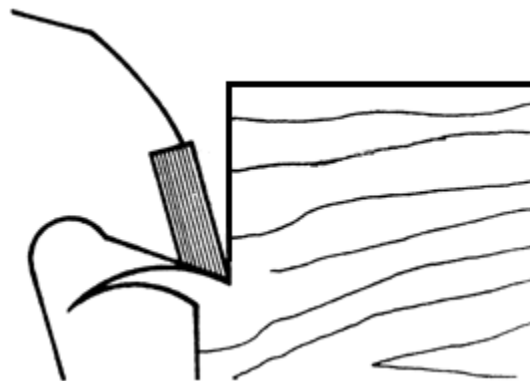

Constituents of the wood

The inorganic constituents fraction (ash content) in particular has an effect on cutting processes and in this case on cutting edge blunting. Silicon dioxide SiO_2 , which is present in amorphous particles, acts as an abrasive. Coconut palm wood has an SiO_2 content between 0.02 % and 0.15 % with an average value, independent of the local distribution, of 0.10 %. The SiO_2 particles (stegmata) are only to be found in densely packed form on the sclerenchymatic sheath of the vascular bundles. This proportion of SiO_2 is relatively small compared to wood species that are well-known for their high, tool-blunting proportion of SiO_2 . The tool-blunting properties of coconut palm wood are probably caused by the large density difference between the vascular bundles and the ground tissue together with the fine dust that is formed during machining.

8.4 Basics of wood machining

Cutting speed

The cutting speed is the speed of the tool cutting edges during the cutting movement into the workpiece. It is calculated by the formula:

$V_c = D \times \pi \times n / 60 \times 1000$ [m/s]	
V_c	=Cutting speed
D	= Tool diameter [mm]
n	= Revolutions per minute [min^{-1}] (rpm)
π	= 3,14

The following Table 21 shows the usual range of cutting speed for machining solid wood.

Table 21: Cutting speeds for solid wood

Machinind method	Cutting speed (m/s)
Sawing	60- 100
Planing and moulding	20-60
Sanding	20-40

The cutting speed is chosen with regard to several technical and economic criteria such as type of material, quality of cut, cutting tool wear and quantitative output. As a rule, higher cutting speeds allow larger feed speeds and thus a higher quantitative output under otherwise identical machining conditions. However the tool construction must be designed for the selected cutting speed. In addition it is generally true to say that the quality of cut under otherwise identical conditions increases at higher cutting speeds, but that the technical effort to implement higher cutting speeds and the cutter wear also increase. This means that there is an optimum cutting speed for each application, taking the technical and financial criteria into account.

Feed speed

The feed speed V , [m/min] is the speed of the forward feed movement of the workpiece or of the tool. The feed speed is proportional to the feed per tooth f_z and is essentially responsible for the quantitative output. It is calculated by the formula:

$V_f = f_z \times z / 1000$ [m/min]	
V_f	= Feed speed [m/min]
f_z	= Feed per tooth [mm]
n	= Revolutions per minute
z	= Number of cutting

When machining solid wood feed speeds range from 1 - 220 m/min with a highest frequency of occurrence in the range 5 -25 m/min. High feed speeds require large technical expenditure on tool construction, machine design, workpiece guidance, power demand etc.

Because of the high density of the material and resulting extreme cutting conditions, the higher feed speeds cannot be used with several methods with Cocos n. HD.

Feed per tooth

The length of the path through which the workpiece moves during cutting between the engagement of two consecutive cutting edges is called the feed per tooth f_z . It is proportional to the feed speed V_f and is calculated by the formula:

$f_z = V_f \times 1000 / n \times z$ [mm]	
V_f	= Feed speed [m/min]
f_z	= Feed per tooth [mm]
n	= Revolution speed
z	= Number of cutting

Sample calculation:
- Cutter block with 2 knives
- Feed speed: 7 m/min
- Revolution speed: 3600 min ⁻¹
Feed per tooth:
$f_z = 7 \text{ m/min} \times 1000 \text{ mm/m} / 3600 \text{ min}^{-1} \times 2$
$f_z = 1 \text{ mm}$

It follows from this that doubling the number of cutting edges (4 knives instead of 2) also enables the feed speed and thus the quantitative output to be doubled, theoretically with the same quality.

The feed per tooth is a technical coefficient. It can be affected by the feed speed V_f , the revolution speed n and the number of teeth z . As the feed per tooth decreases, the cutting forces become smaller, the average chip thickness becomes less and thus the cut surface quality becomes higher. The "feed per tooth" is identical with the "length of the cutter marks" and therefore a parameter for the surface quality of the respective cutting process. However it is also necessary to take account of the fact that if the chip thickness is too small, the cutting edges partly slip over the wood with a shaving effect, which leads to increased tool wear, and that as a rule the quantitative output decreases proportionally at small feed speeds.

Section 8.6 explicitly states the feed per tooth for the respective machining processes.

Pre-splitting (cleaving)

Because of the anisotropy and operating conditions, pre-splitting may occur with coconut palm wood. The chip is separated from the wood not by the surface of the cutters but by a cleavage process preceding it (see Figure 69). Provided that the wood grain runs outwards, a surface corresponding to the operating conditions is obtained. If the grain runs into the wood, irregular surfaces are obtained as a rule, since the chip is larger than the pre-determined size and breaks away in an uncontrolled manner.

The danger of pre-splitting also increases with increasing chip thickness.

Fig. 69: Pre-splitting during up-cutting

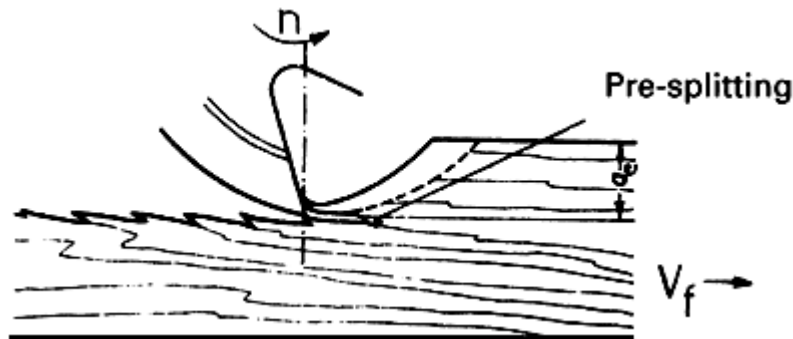

Down-cutting and up-cutting Down-cutting

In a down-cut operation, the cutting movement of the cutting edge and the relative feed movement of the workpiece are in the same direction. The cut into the comma-shaped chip starts at its thickest point and its thickness decreases down to nil.

Advantages: Clean cut surfaces are produced even when the grain (fibre) direction is unfavourable and with a small feed force. It is possible to use high feed speeds.

Disadvantage s: The life span (until blunt) is smaller because of the smaller amount of pre-splitting and the knife edge rubbing the timber after cutting. Down-cutting is suitable only for mechanical feed.

Caution!!
Accident hazard
Do not operate in down-cut with manual feed!

Up-cutting

In an up-cutting operation, the cutting movement of the cutting blade and the relative feed movement of the workpiece are in opposite direction. The cut into the chip starts at its thinnest point and its thickness increases up to the cutter blade exit.

Advantages: Up-cutting results in longer life spans than down-cutting because of pre-splitting and the more favourable cutting edge engagement geometry. The cutting forces are reduced.

Disadvantage s: Splintering and poor surface qualities can be produced with up-cutting, if the grain is poor, because of the increased extent of pre-splitting.

8.5 General remarks on tool and machine design

8.5.1 Machine characteristics

The results of a wood machining operation can be affected greatly by the design and construction as well as the current technical condition of a woodworking machine. Basically the woodworking machine should fulfil the functional requirements derived from the machining tasks. Further operational requirements in addition to these purpose-dependent functional requirements arise from the use and operation of the machine, such as accident safety, profitability, environmental friendliness etc.

Disturbances in the machining system occur if the functional and/or operational requirements are not fulfilled, and have a negative effect on the result of the operation with respect to work quality and (quantitative) output of work. The causes of the disturbances emanating from the woodworking machine can be very varied. Thus, in addition to incorrectly dimensioned machine elements, inadequate maintenance and repair can also be responsible for breakdowns of this kind. Frequent causes leading to inadequate work quality and/or output include concentric running inaccuracies in the tool and/or tool spindle area that can arise as a result of bearing play, excessive tolerances between the location hole of the tool and the spindle, or as a result of the tool itself. For tolerable deviations see Table 22.

Table 22: Tolerances on the machine

Run-out error at the saw flange:	< 0.02 mm.
Concentric running error at the planer or shaper	< 0.02 mm.

With regard to their design and construction, machines for working coconut palm wood must be designed for machining "heavy" woods. Limitations resulting from the woodworking machine may become apparent when machining high density coconut wood under certain operating conditions. This manifests itself by, for example, extreme vibration, very loud operating noises and by the poor quality of the machining.

The machining of coconut palm wood of medium and high density requires heavy dimensioning of:

- the machine base
- the motors
- the bearings and guides
- the templates and jigs.

In contrast to other types of wood, a large proportion of dust and chips with very small particle sizes is formed when machining coconut palm wood. They require design precautions

- against the escape of dust and chips from the area where they are formed into the surrounding air.
- against the penetration of the dust into the machine bearings, which leads to damage if the latter are not appropriately sealed.

This means that dust and chips must be removed effectively from the working area, preferably by pneumatically operating suction devices. On some occasions water is applied to the kerf area and onto the saw-blade. The effect of this is to cool the tool and to suppress the dust. A comparable effect occurs when machining "wet" wood.

Important

- Machines/relevant components must be heavily dimensioned!
- Chips and dust must be removed effectively from the working area!

8.5.2 Tool characteristics

Machine tools are the carriers for the cutter knives needed for chip-cutting. A distinction is made between construction types according to the following Table 23.

Table 23: Tool construction types

Tool construction types	Use
<p>Solid tools (one-piece tools) Cutter knives and body are made of a single material throughout.</p>	HSS drills CV saw blades HSS/HL cutter blocks
<p>Tipped tools The cutting tips are fastened to the support body (brazed, welded) and are made of wear-resistant material.</p>	TC boring bits TC/Stellite saw blades and cutter block
<p>Composite tools Fastening elements clamp the knives onto the carrier body, usually with positive attachment. Advantage: quick knife changing.</p>	Reversible tip drills/cutter blocks Tipped cutter block/cutter heads
<p>Cutter sets At least 2 tools together with distance rings are combined into one unit in order to carry out several work operations in a single pass.</p>	E.g. windowframe profile sets
<p>System tools (sets of tools) Tool sets matched to one another for standard profiles.</p>	E.g. tongue and groove cutter sets

Chip thickness limitation

Saw-blades, cutter blocks and heads for manual feed are of limited chip thickness construction in order to reduce the risk of accidents. The deflector that prevents the workpiece being pulled into the tool is located in front of the cutter knife and the gullet (see Figure 70).

Fig. 70: Chip thickness limitation

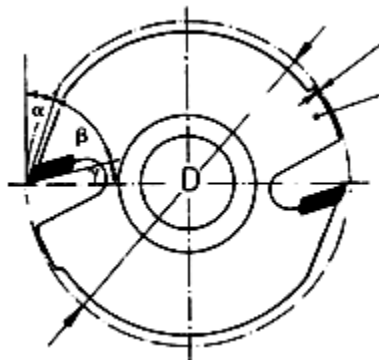

**Caution!!
Accident hazard**

Use only limited chip thickness tools with manual feed!

Cutting edge material

Four groups of cutting edge materials are used when machining solid wood:

- HL = High-alloy steel
- HSS = High-speed steel
- TC = Tungsten carbide
- Stellite

Tungsten carbide and stellite should be used as the preferred cutting edge material for the efficient and economic machining of coconut palm wood. Boring bits are the only case in which HSS can be used without serious disadvantages.

Wear and lifetime

The lifetime of the cutting edge is an important parameter for the economic-technical utilization of coconut palm wood. Lifetime means the time that elapses before a newly-sharpened tool no longer fulfils its specified function. This usually occurs as a result of cutting edge blunting or cutter breakage (= wear).

In woodworking, surface quality is an essential quality criterion, depending on the product, intended use etc. If a specified quality is no longer achieved, the tool or the cutter knife is replaced or re-sharpened. However the assessment of surface quality takes place subjectively based on the quality demands that are needed, i.e. cannot be defined unambiguously. There is a lack of suitable measurement methods that are usable in actual practice and which can determine the complex shape of a surface and its quality sufficiently well and quickly and which can be used to assess them.

Important

The sharpness of the cutting edge is an important parameter affecting surface quality and the profitability of a cutting process!

Cutting edge geometry

In addition to the cutter knife material, the cutting edge geometry has a great effect on surface quality, power requirement and lifetime. From the numerous influences on the cutting angle, only global statements can be made. Ultimately the optimum angles are derived from experience. Cutting edge geometries of the kind used when machining "heavy" tropical woods with abrasive properties apply to the working of medium and high density coconut palm wood.

Tolerances

The question as to how many cutting edges shape the surface or whether they merely pre-cut and do not participate in creating the surface depends on the order of magnitude of the tool tolerances (see Table 24).

Table 24: Tool tolerances

Cutting circle tolerance in peripheral cutting:	0.02-0.03 mm.
Run-out error in circular sawing:	< 0.1 mm.
Tool holder fitting:	H7.

Important

All of the cutting edges present on the tool should participate equally in the chip-cutting process and in the creation of the surface!

Tool requirements

Tool lifetimes are relatively short because of the high cutting edge wear with coconut palm wood. Frequent changing of cutting knives or tools is necessary. This leads to several requirements and consequences relating to the tools for working coconut palm wood:

- Several tools or cutter knives of the same construction must be available for continuous machining on an industrial scale.
- Tipped and composite tools are preferable, since as a rule they are fitted with wear-resistant cutting edge materials (TC, stellite).
- The changing of cutter knives or tools should cause only short machine stoppages. The machines and tools should be designed for this.
- The use of TC reversible tips and of mechanized tool-changing systems should be examined carefully.
- The required sharpening equipment in the factory must be designed for these requirements, especially when the need for continuous operation must be fulfilled.

Care and maintenance of tools

Dust deposits on the cutter knives and becomes compacted into a layer when machining coconut palm wood. This increases friction and leads to heating and premature wear of the cutting edges and to some extent of the tools themselves. The dust deposit must be cleaned from the tools regularly by using cleaning baths. Cleaning baths must be used in accordance with the manufacturer's instructions because they involve corrosive chemicals. Tool maintenance must be carried out by specially trained personnel since improper sharpening causes the tools to wear out prematurely, reduces their lifetime and thus impairs profitability.

Important

Deposits (compacted coconut wood dust) must be thoroughly cleaned from tools before sharpening the cutting edges in good time!

Caution!!

Cleaning baths consist of corrosive chemicals and must be used carefully (risk of accident and environmental damage)!

8.6 Machining methods in secondary processing

8.6.1 sawing

The main function of sawing is cutting wood to size (cutting to length, trimming, cutting to width) and cutting to shape parallel to and perpendicular to the grain (Figure 71).

Fig. 71: Operating principle of sawing - parallel to the grain (left) and sawing - perpendicular to the grain (right)

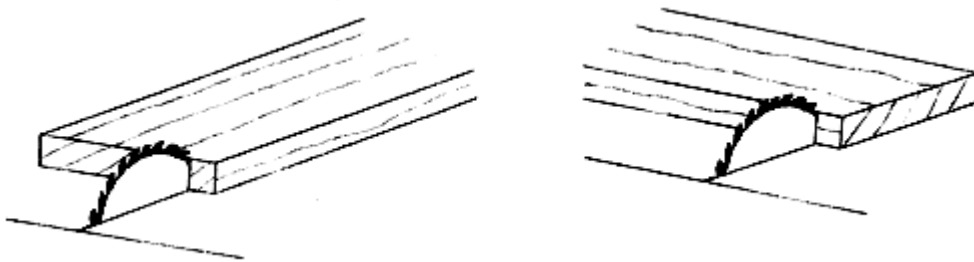

Circular sawing is used for primary processing and secondary processing of sawn timber. Compared to primary processing, considerably smaller cutting heights are required in the secondary processing of sawn timber.

As a very universal method, circular sawing fulfils the following requirements and target parameters to a very large extent during secondary processing:

- high surface quality
- possibility of small cutting losses through the use of thinner saw-blades
- high dimensional accuracy through the least possible "untrue cutting" by the saw tools
- large cutting capacity and from there high feed speeds are possible
- good adaptability to different tasks.

Typical of the machining of solid wood is the following operating sequence for manufacturing prismatic parts {Figure 72):

Fig. 72: Working sequence for prismatic parts

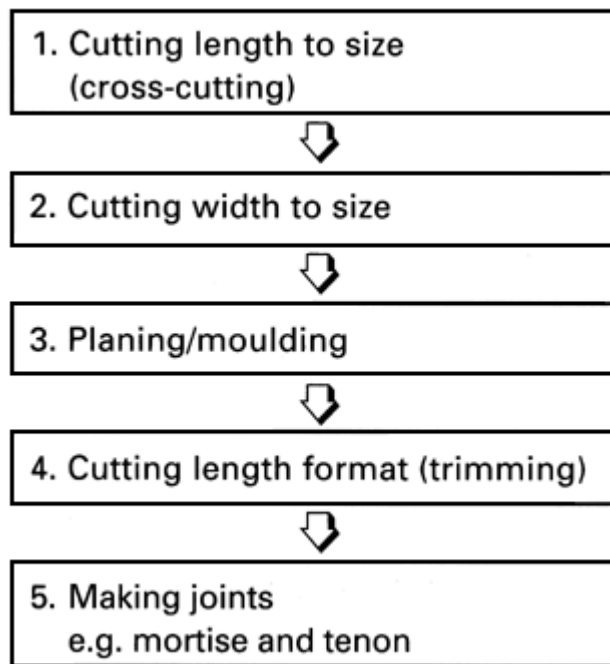

In the work sequence shown above, "circular sawing" is used in work procedures 1,2,4 and 5. Further examples of the versatile use of "circular sawing" in the processing sequences for various products and parts can be found in Chapter 8.2.

The same relationships and principles apply to the cutting technology parameters as for moulding/shaping with peripheral-cutting tools, with the difference that when cutting through wood, the circular saw blade projects above the latter by the distance p (see Figure 73).

Fig. 73: Principle of the circular saw cut (Ettelt, 1987)

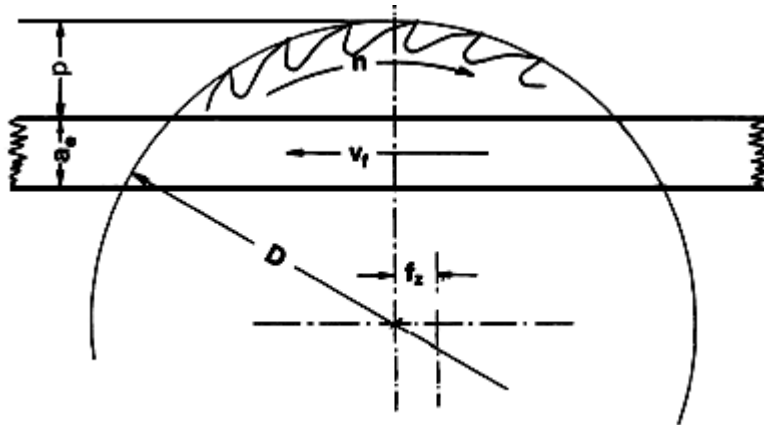

A further peculiarity of circular sawing compared to peripheral shaping is in the creation of the cut surfaces. The lateral "cut surfaces" are generated by the minor cutting edges of the circular saw blade. Thus the quality of the surface is determined essentially by the cutting edge corners and by the blade stiffness and flat-running accuracy of the circular saw blade. Deviations from flat running can arise from the following causes:

- errors in setting/sharpening
- inadequate clamping of the saw-blade
- blade slap
- worn-out saw shaft bearings.

These manifest themselves as circular grooves of unequal depth in the cut surfaces. The quality of the surfaces can also be controlled by the value of the feed per tooth f_z . The cutting forces are reduced as the feed per tooth decreases, the average chip size becomes smaller and thus the quality of the cut edges improves {see also Table 25}.

Table 25: Favourable values for feed per tooth f_z (= length of cutting marks) when circular sawing coconut palm wood

Material	Feed per tooth f_z [mm]
Cocos n. MD, HD	0.05-0.1
Cocos n. LD	0.15-0.5

Important

With large kerfs (thick workpieces, $d > 50$ mm) small feeds per tooth must be used since otherwise the chipping volume per tooth is too large!

Technical construction of circular saw-blades

Circular saw-blades differ in their cutting edge angle, number of cutting edges for the same diameter (pitch), tooth form and cutting edge material. These parameters must be matched to the use and intended purpose (see Figure 74 and Table 26).

Fig. 74: Cutting angles - circular saw-blade (see also Figure 29)

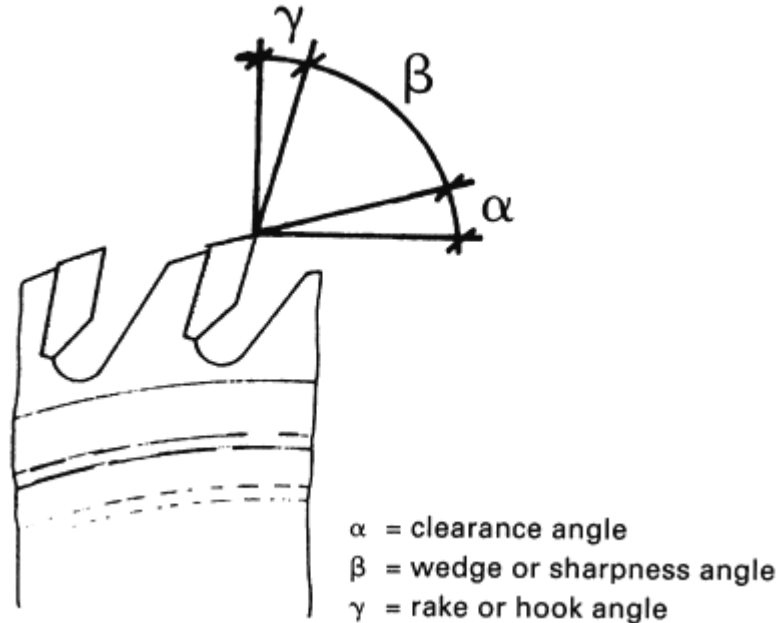

The tooth ends on untipped saw-blades (HL, HSS) (Photo 45a) are bent outwards (set) in alternating directions in order to obtain a kerf that is wider than the thickness of the plate. This avoids friction between the plate and the cut surface. On saw-blades tipped with hard metal or stellite, the tooth width is greater than the plate (see Figure 75 and Photo 45 b). This again avoids friction against the cut surface. The rake angle γ is always positive when machining palm wood and should be between 15° and 20° for longitudinal cuts in Cocos n. MD and HD. As a rule, tipped circular saw blades used in secondary processing are not re-tipped after the cutting edges have been completely used up.

Fig. 75: TC tooth shapes

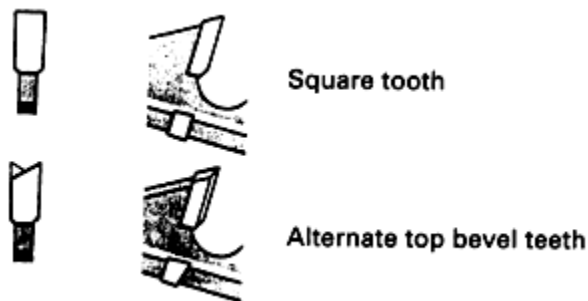

Photo 45 a: Solid (one-piece) saw-blade

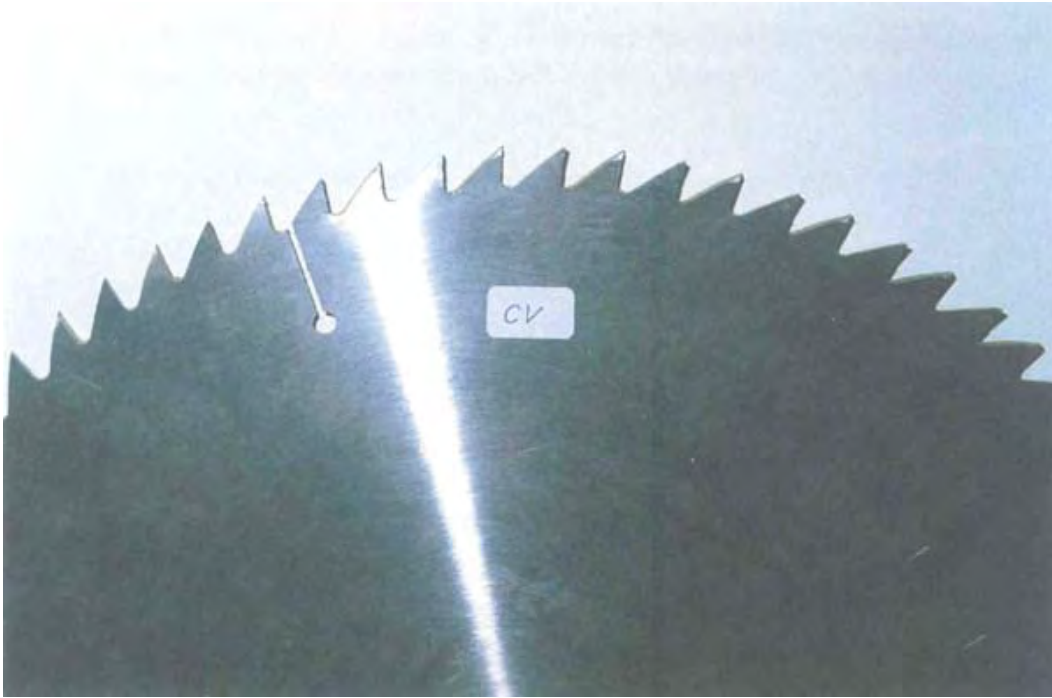

Photo 45 b: TCT-saw-blade

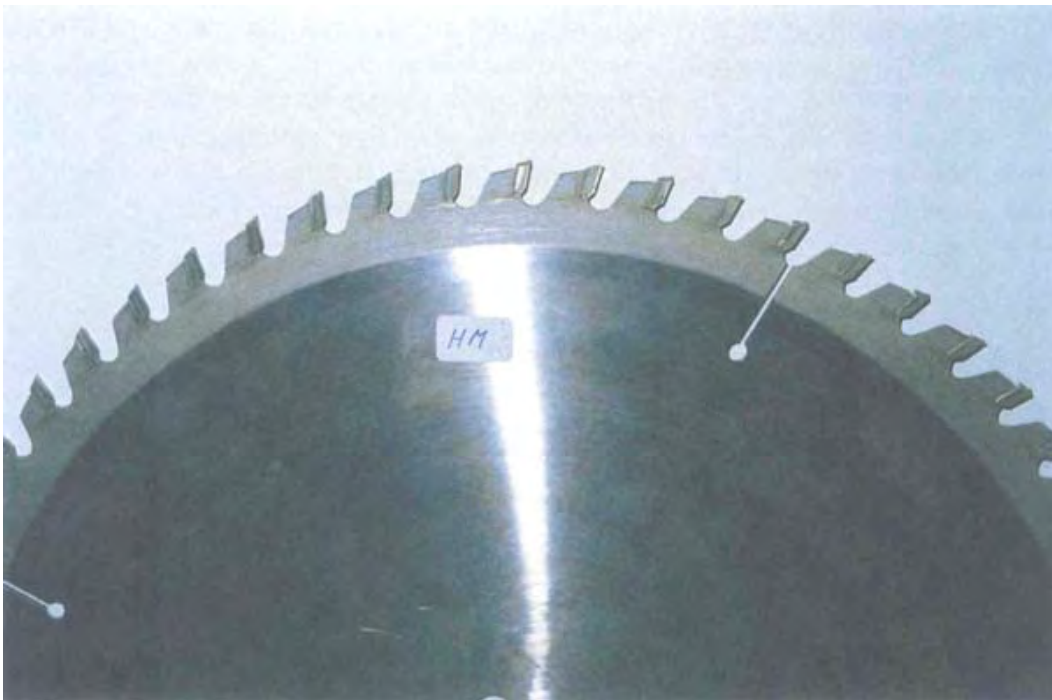

Table 26: TCT circular saw blades for machining coconut palm wood

Type of use	Tooth shape	Tooth width (mm)	Wedge angle	Rake angle (°) Y
Cutting length and width to	Square tooth	20-40	55	20
Format cut	Alternate top bevel teeth	20-40	60	15

Technical requirements applying to circular saw machines

The numerous tasks that can be handled with circular saws are carried out partly on special machines and partly on universal machines. Typical machines are listed in the following Table 27.

Table 27: Circular saw machines and their application

Operation	Machine
Cutting to length	Cross-cutting saw, multiple length-trimming saw, radial arm
Cutting to width/ripping/edging	Table saw, dimension saw, multi-rip saw, edger
Rabbeting, grooving	Table saw, dimension saw
Dimensioning/format cutting	Dimension saw, twin dimension saw
Processing corner joints for frames and boxes	Table saw, dimension saw, twin dimension saw, radial arm saw, tenoning machine

The dimension saw (Photo 46) with the following facilities can be regarded as the basic machine:

- Fence
- Mitre-gauge with stop-block
- Edge-trimming slides
- Cutting height adjustment
- Tilting arbor
- Revolution speed adjustment
- Suction nozzles
- Riving knife ("splitter") and topguard

The feed can be manual or by mechanical feed devices.

Photo 46: Dimension saw (sliding table saw)

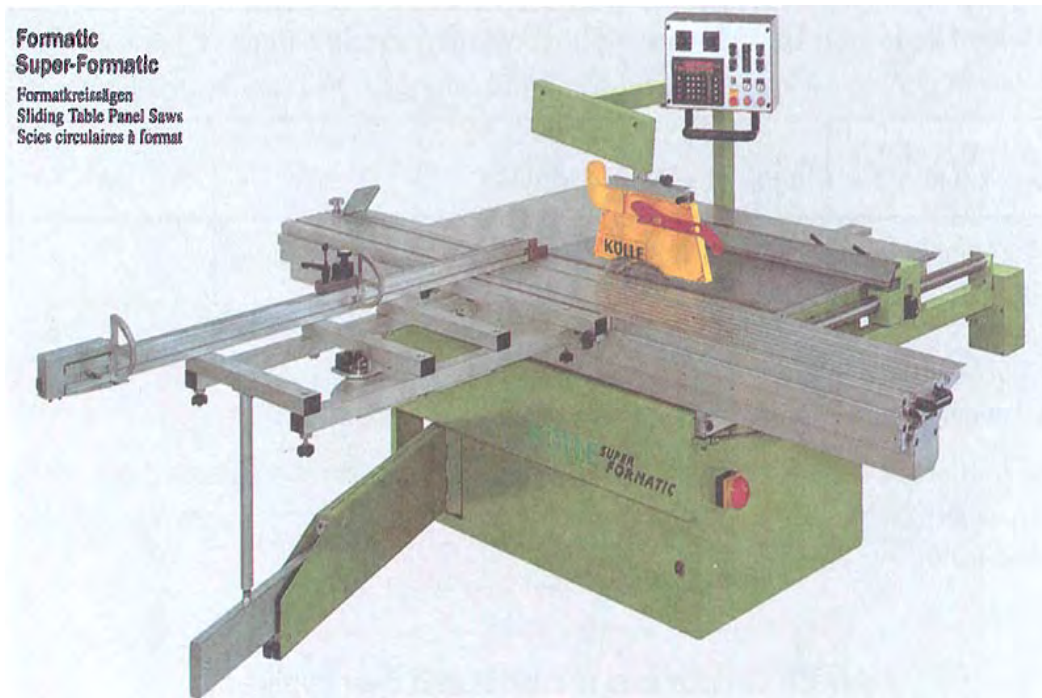

User information for circular sawing of coconut palm wood

Cocos n. MD and Cocos n. HD show edge splintering to some extent when sawing parallel and perpendicular to the grain. The parenchyma breaks out because of its low intrinsic strength. The extent of splintering depends, among other things, on the machining parameters (f_z , V_c) and must be included in the amount of allowance given for subsequent machining steps (planing, moulding). In addition, as a rule vascular bundles protrude from the workpiece surface after sawing along the grain.

Splinters of the kind that are formed at the back edge of the workpiece (saw exit edge) when sawing at right angles to the grain can be prevented by the use of stop-blocks (Figure 76).

Fig. 76: Use of a stop-block

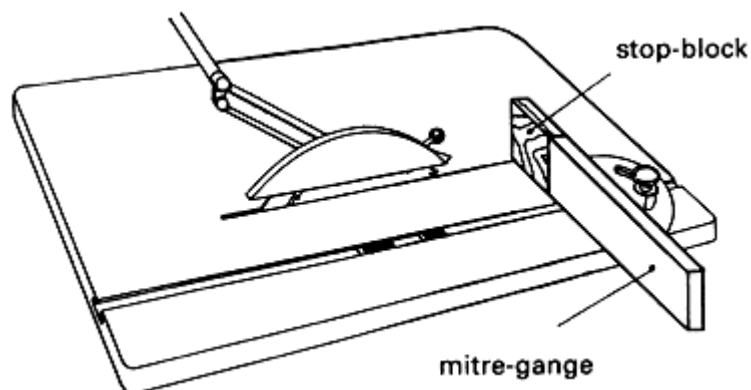

For Cocos n. MD and Cocosn. HD it is true to say that good cut surfaces and cut edges can be produced when sawing with a small feed per tooth ($f_z = 0.05 \text{ mm}, 0.1 \text{ mm}$) and when using TC cutting tips. When machining Cocos n., the effects of different cutting speeds and saw-blade projections p are rather small with TCT tools (Table 28). Compared to stellite-tipped saw-blades, TCT saw-blades achieved both considerably better cut surface qualities and longer life spans. Cocos n. HD is only inadequately machinable with chromium-vanadium saw-blades, while thick workpieces ($d > 50 \text{ mm}$) are not at all machinable with these.

Despite the higher procurement and maintenance costs of TCT saw-blades as compared to stellite-tipped ones, the lower processing costs are achieved with TCT tools.

Table 28: Technical data for circular sawing Cocos n. parallel and perpendicular to the grain

Feed per tooth f_z (mm):	0.05-0.1.
Cutting speed V_c (m/s):	60 - 90.
Cutting edge material:	TC, Stellite.

Important

- Coconut palm wood must be sawn with TC- or stellite-tipped saw-blades at low feed per tooth!
- Stop-blocks must be used to prevent splintering in dimensioning at right angles to the grain!

8.6.2 Narrow band-sawing

The main function of band-sawing in secondary processing (see Figure 77) is the division and curve-sawing of wood. Considerably smaller cutting heights are needed when secondary processing of sawn timber is compared to primary processing. Narrow band-sawing largely fulfils the following requirements and target parameters, especially during secondary processing:

- Low cutting losses due to small saw kerf width
- Curve-cutting is possible.

Narrow band-sawing is used when "sawing out the shape" in the working example "Chair back legs" in Section 8.2.

Fig. 77: Operating principle of narrow band-sawing (sawing of curved or irregularly shaped outlines)

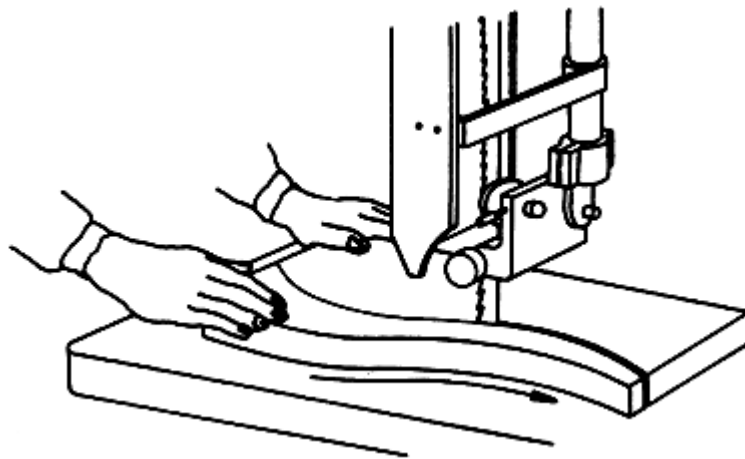

As with circular sawing, the cut surface is generated by the minor cutting edges. Thus the quality of the cut surface is determined essentially by the cutting edge corners and by the blade stiffness and blade guidance. The cut surface quality is also affected by the feed per tooth f_z . The cutting forces become less, the average chip thickness smaller and thus the cut surface quality higher as the feed per tooth decreases (see Figure 78).

Deviations from the cut quality are characterized in particular by grooves whose causes lie in the tool/machine area:

- Setting/sharpening errors
- Inadequate saw-blade clamping
- "Worn out" bearings
- Defective saw-blade guides
- Faulty table mouth piece

Fig, 78: Technical parameters of band-saw blades

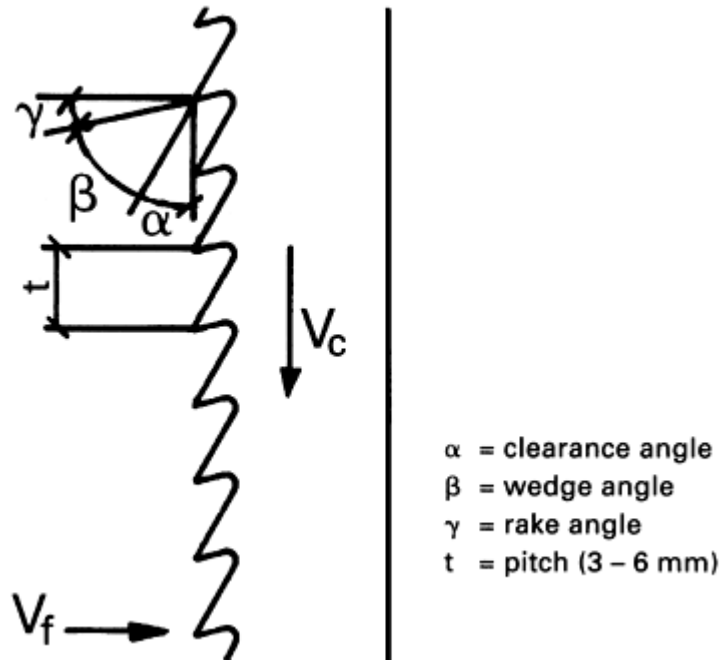

Technical construction of band-saw blades

Band-saw blades consist of chromium-nickel steel. Their thickness is 1/1000th of the wheel diameter of the band-saw machine.

Their width, pitch and tooth geometry are governed by the curve radius that is to be produced and by the engagement depth (material thickness) (see Table 29).

Table 29: Machining coconut palm wood with band-saw blades

	Wedge angle ($^{\circ}$) β	Rake angle ($^{\circ}$) γ
Curve cut	50	15-20

So that the saw-blade does not rub against the cut surface, the teeth must have a lateral overhang (set) which is achieved by setting, upsetting or by using teeth with laterally projecting cutting edges, e.g. as with stellite-tipped band-saw blades. The tooth tips can be hardened by high frequency equipment and thus achieve a longer lifetime. TCT band-saw blades are not used in woodworking.

Technical design of band-saw machines (Photo 47)

As a rule the feed on narrow band-saws is manual. In addition to a good band-saw guidance, a table mouth piece surrounds the saw-blade well should be used (Figure 79), which of course must be changed in accordance to wear. The table mouth piece supports the lower surface of the workpiece and thus helps to avoid splintering at the saw exit edge.

Photo 47: Narrow band-sawing machine



Fig. 79: Table mouth piece

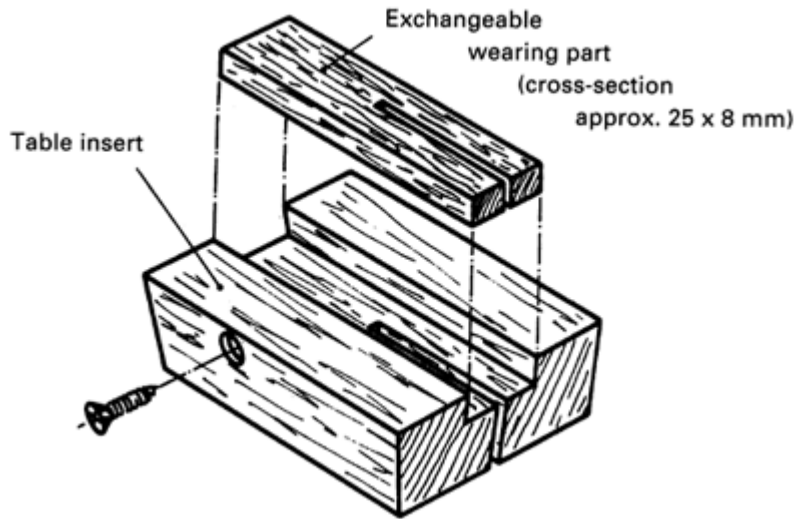

The cutting speeds (see Table 30) on table band-saws are between 25 and 35 m/s. The cutting speed V_c is calculated as follows:

$V_c = D \times \pi \times n / 60$ [m/s]
D = Wheel diameter [m]
V_c = Cutting speed [m/s]
n = Wheel revolution speed [min^{-1}]

User information for narrow band-sawing of coconut palm wood

The cut surface quality with all density classes is good to very good when using work-sharp band-saw blades. The "grooves" produced by the saw-blade appear to a lesser extent at higher raw density and lower feed speed. Splintering occurs especially during cross-grain cutting and when sawing against the grain.

The life distance of the saw-blades is a problem when machining coconut palm wood, since chrome-nickel steel saw-blades are used here. Depending on the density range, chip removal volume and number of teeth, the life distances that are achievable are only twice to five times the saw-blade length. The cut surface quality and the splintering on the workpiece underside very soon reach a magnitude that is no longer tolerable for further processing (e.g. shaping/moulding). The machining allowances must then be disproportionately large (5 to 10 mm) to enable the resulting defects to be removed. The technical data for band-sawing are summarized in the Table 30:

Table 30: Technical data for band-sawing

Cutting speed V_c (m/s): ca. 30.

Cutting edge material: CN-hardened, Stellite.

Important

Coconut palm wood must be sawn using hardened band-saw blades!

8.6.3 Planing (Peripheral flat planing)

As a rule, planing {see Figure 80) and profiling follow the work sequences of cutting to length (trimming) and cutting to width.

Fig. 80: Working principle of planing

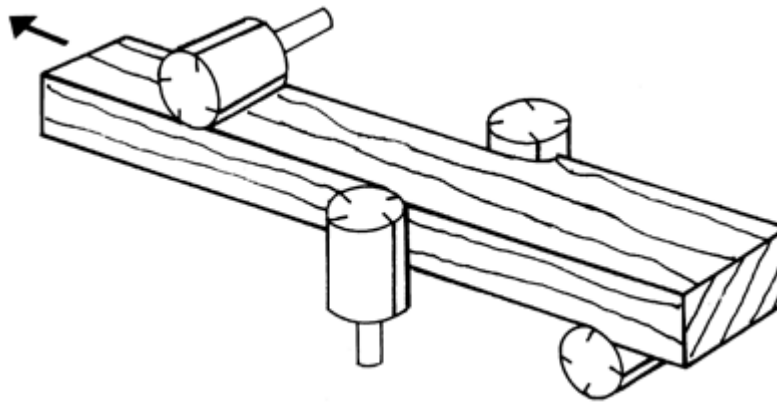

The following operations are needed to produce prismatic parts:

1. Surfacing



2. Square edge and width planing



3. Thickness planing

In peripheral planing, the cutting edge enters the workpiece and removes a comma-shaped chip at its peripheral path. On the workpiece the cutting edge produces a curved surface corresponding to the chip shape. The next cutting edge enters the workpiece displaced through a distance equal to the feed per tooth f_z and again removes a chip (see Figure 81). A curved surface corresponding to the chip shape and called the cutter mark is formed on the workpiece. The length of the cutter mark corresponds to the feed per tooth f_z .

- f_z = Feed per tooth (= length of cutter
- a_e = Cutting depth
- D = Toot diameter/cutting diameter

Fig. 81: Parameters on the chip in peripheral planing

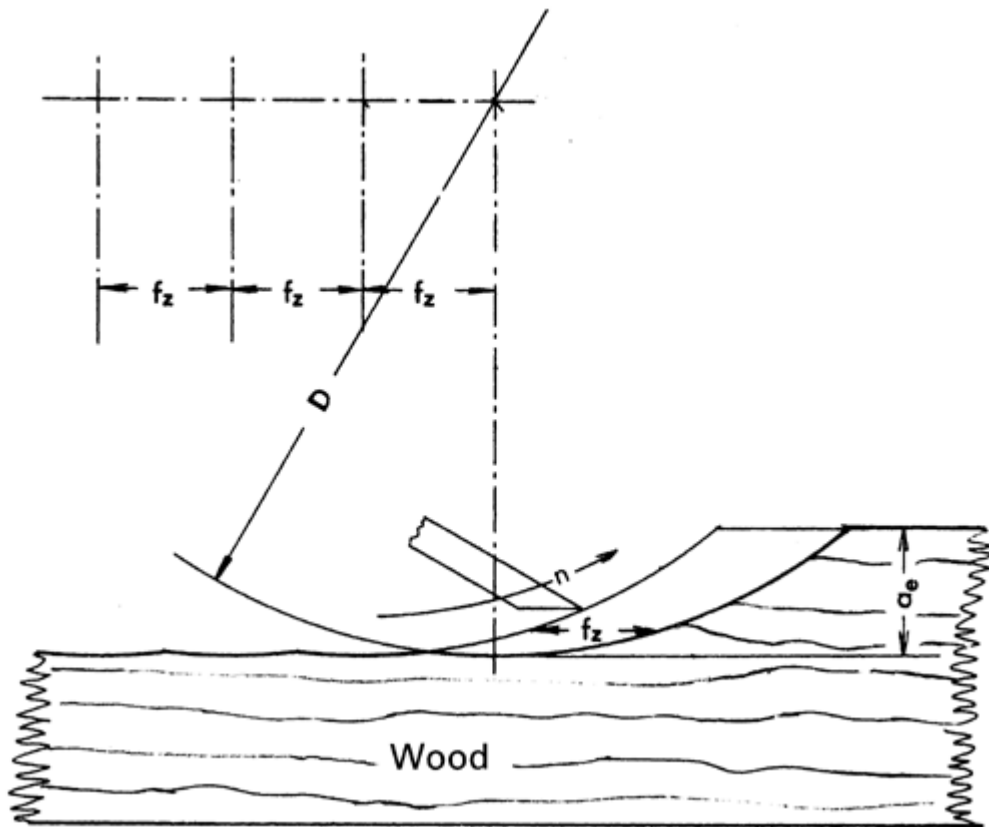

Table 31 shows the surface quality depending on the length of the cutter marks.

Table 31: Surface quality

Surface quality	Feed per tooth f_z length of cutter marks
Smooth	0.3 - 0.8
Medium	0.8-2.5
Rough	>2.5

The appropriate length of cutter marks (= surface quality) depending on feed speed, r.p.m., and number of knives can be read from the following graph (Figure 82):

Fig. 82: Graph of the theoretical length of cutter marks/feed speed/ surface quality

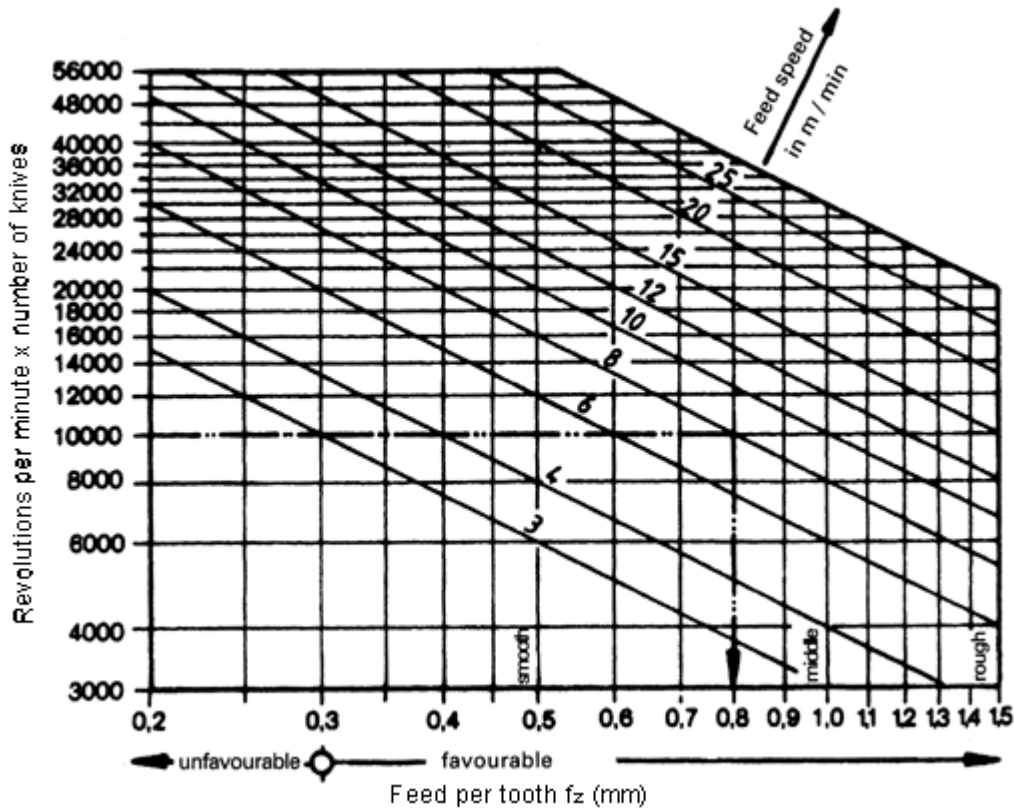

(Source: Letiz)

Actual length of cutter marks

In peripheral planing, the manufacturing and adjustment inaccuracies of the machine and tool system affect the surface quality and cutting edge blunting and already cause a considerable deterioration of the surface quality even at moderate feed speeds, since as a rule with tools having two cutting edges, only one cutting edge forms the surface while the second cutting edge only pre-cuts (Figure 83).

Fig. 83: Actual length of cutter marks

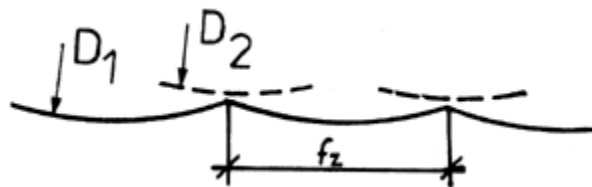

D_1, D_2 : Cutting diameter of cutting edges 1 and 2.

Technical information for cutter heads

The following actions are taken to achieve the same cutting circle for all of the available cutting edges:

- sharpening the blades in situ in the blade shaft
- use of self-centring, exchangeable knives (turn blades)
- use of a hydraulically clamped tool (Figure 84)
- sharpening the cutter heads in the machine (jointing, only with a hydraulically-clamped tool).

Fig. 84: Hydraulic clamping

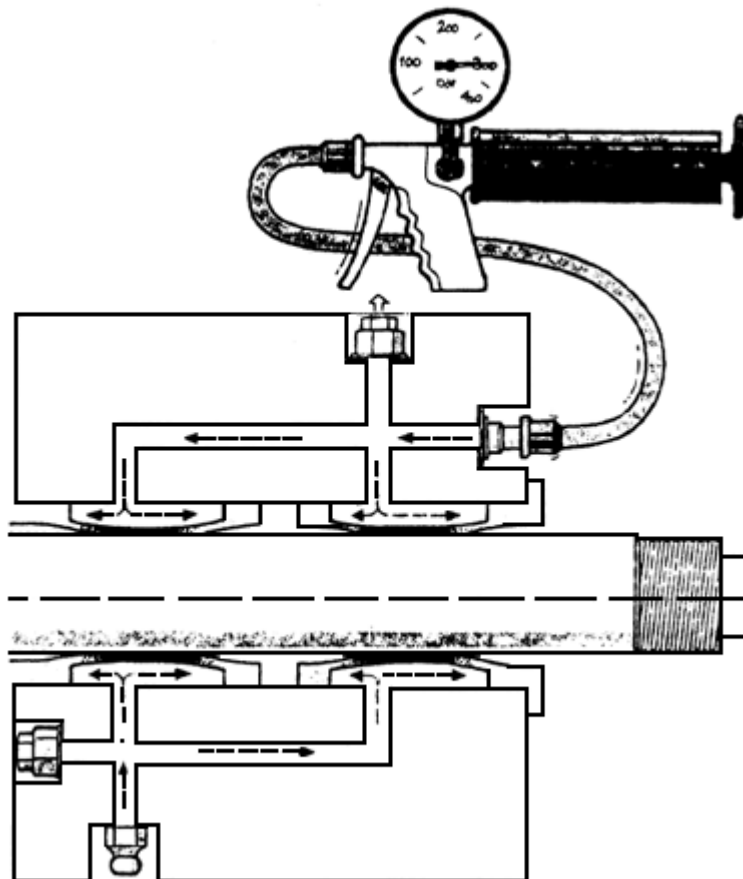

Coconut palm wood, which has an abrasive action, should be machined using knives tipped with TC/stellite. The tool parameters are given in the following Table 32.

Table 32: Cutting angles when planing and moulding coconut palm wood with TC blades

	Wedge angle (°) β	Rake angle (°) γ
Planing	60	15
Milling	55	20

Technical design of planing machines

Normally universal machines are used for planing. It may be advantageous to use four-side planing machines (see Photo 48) for machining rather large amounts of the same cross-section. Compared to the combination surface planer/thickness planing machine, the four-edge planing machine with mechanical feed has the disadvantage of a small passage width (= max. workpiece width) but as a multistage machine it can machine the workpieces on all of the long sides in one pass (often in conjunction with profiling).

Table 33: Planing machines and their application

Operation	Mechine
Surfacing/square edge planing	Surface planer, four-side planing machine
Planing thickness/width	Four-side planing machine, thickness planing machine

Photo 48: Four-side planing/moulding machine

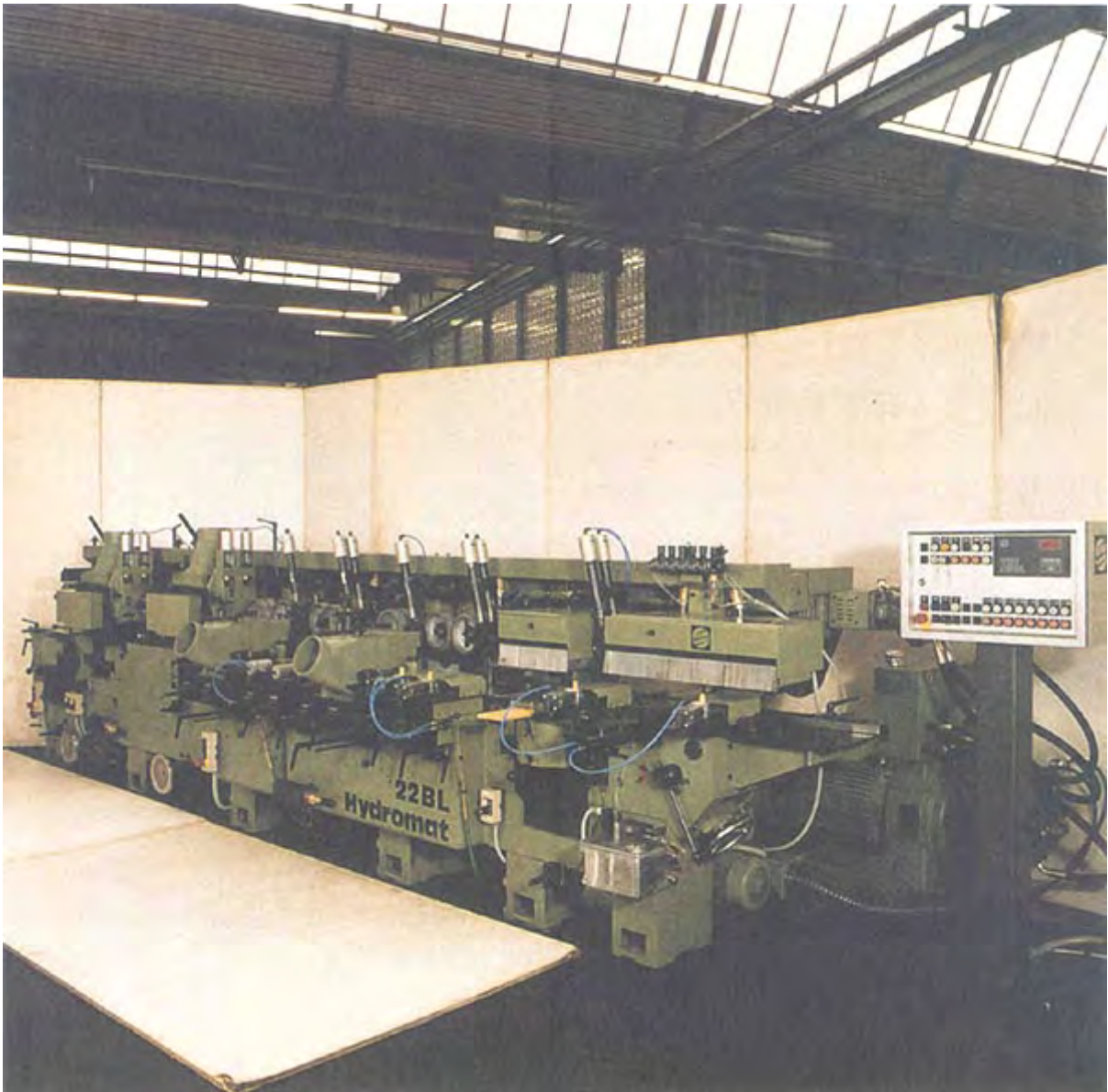

User information for planing coconut palm wood

Achieving the specified surface quality depends essentially on the value of the feed per tooth f_z . With Cocos n. MD and HD, good surfaces are achieved in an f_z range of 0.5 - 1 mm (see also Table 34). This range must be ensured by suitable tooling systems. TC cutting edges show the best results when planing coconut palm wood of medium and high density. Stellite-tipped planing blades are inclined to blunt and then produce splintered back and broken-out surfaces. HSS planing blades are unsuitable and should be avoided if possible.

The parenchyma is more likely to break out when planing with the grain (vascular bundles), and the vascular bundles are more likely to splinter back when planing against the grain. Fibres splintered back can be sanded off well afterwards (see also Chapter 8.6.7). However they prevent the workpieces to converge closely (= tightness) during glue bonding which may lead to a thick glue line and inadequate strength.

Because of the structure, Cocos n. MD and Cocos n. HD are highly prone to edge splintering. The edge splintering and tool wear can be reduced by a small cutting depth a_e . As a rule with sawing, a reduced cutting depth demands a good surface quality from the preceding cutting process.

Table 34: Technical data for planing

Feed per tooth f_z [mm]:	0.5-1.
Cutting speed V_c [m/s]:	ca. 40.
Cutting edge material:	TC.
Cutting depth a_e :	as small as possible.

8.6.4 Profiling/moulding

From the cutting technology point of view, moulding (Figure 85) corresponds to planing, which is dealt with in Section 8.6.3.

Fig. 85: Operating principle of moulding - parallel to the grain (left) and - perpendicular to the grain (right)

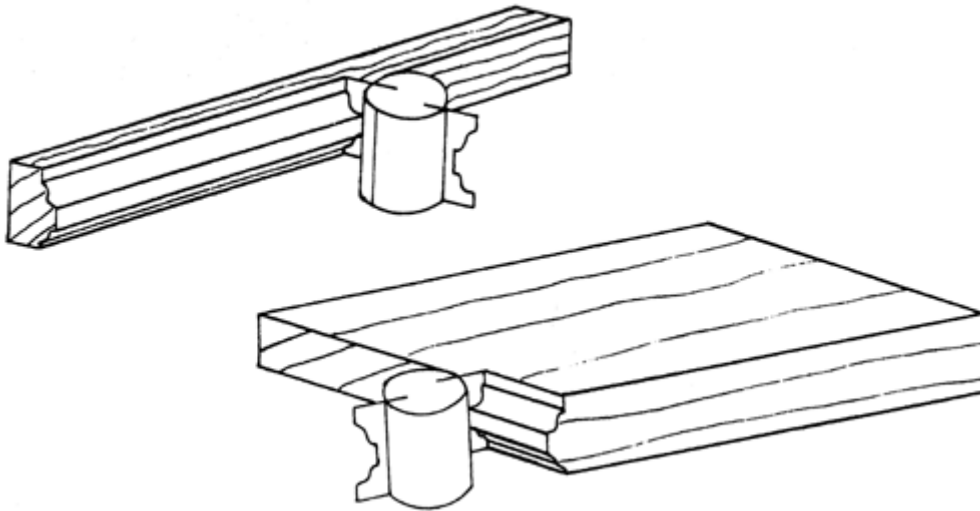

The shaping of curved surfaces and edges of the kind that occurs in the working sequence for the chair leg (Chapter 8.2.2) can be controlled mechanically (copying template with copying pin or roller collar; Figures 86, 87) or program-controlled (CNC-control).

**Technical design of cutter heads for spindle shapers/moulders
(see Photos 49-51)**

The tool construction types are described in Section 8.5.2. A universal cutter head with exchangeable profile knives and limitors illustrated in Photo 51 is especially suited when using different profile shapes. Coconut palm wood must be machined with TC/Stellite-tipped cutting edges, which enable good operating results. The cutting angles should be designed for machining hardwoods. The following table (Table 35) shows cutting angles with which good operating results have been achieved.

Table 35: Tool angle when shaping coconut palm wood with TC knives

	Wedge angle (α)B	Reke angle
Profile shaping/moulding along the grain	55	20

Photo 49: Cutter with cutting tips of stellite or TC

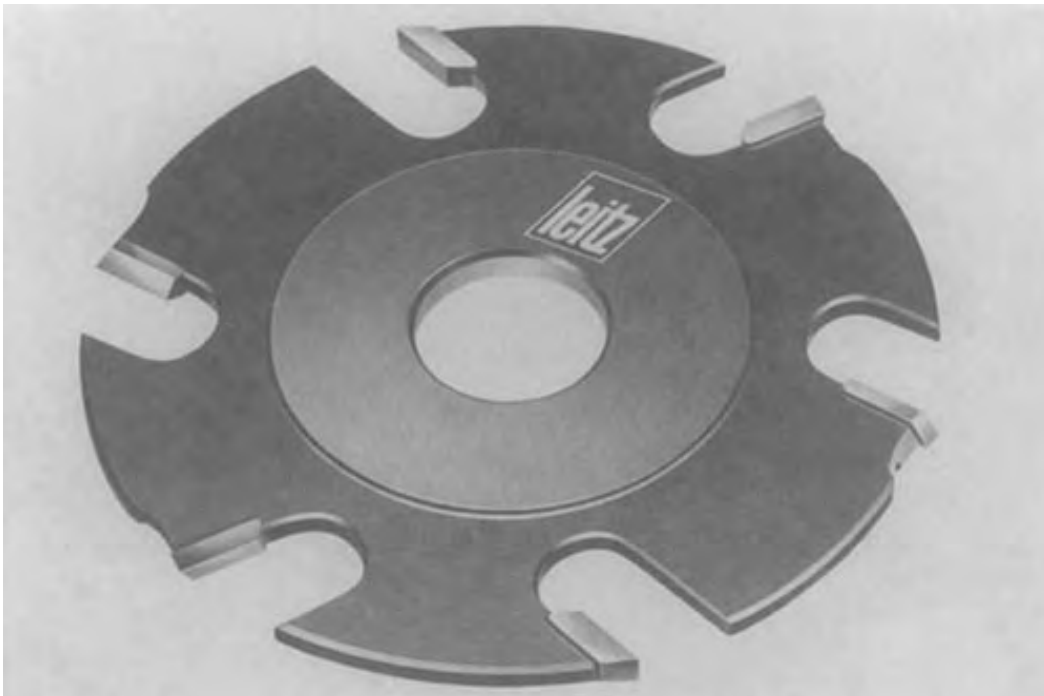

Photo 50: TC-tipped shank type cutter for router

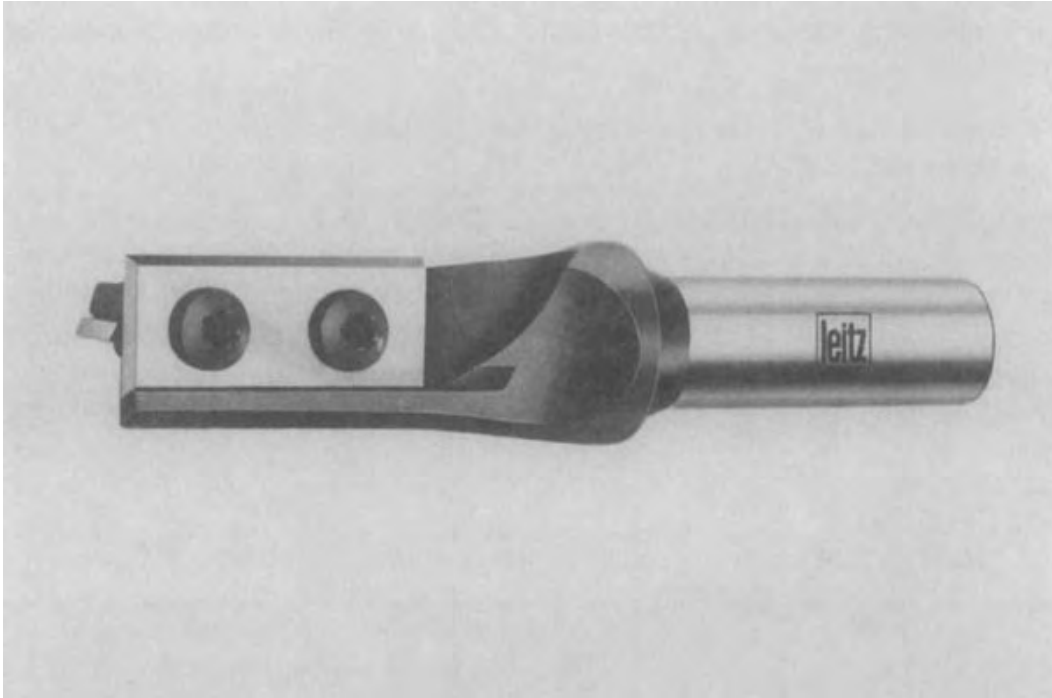
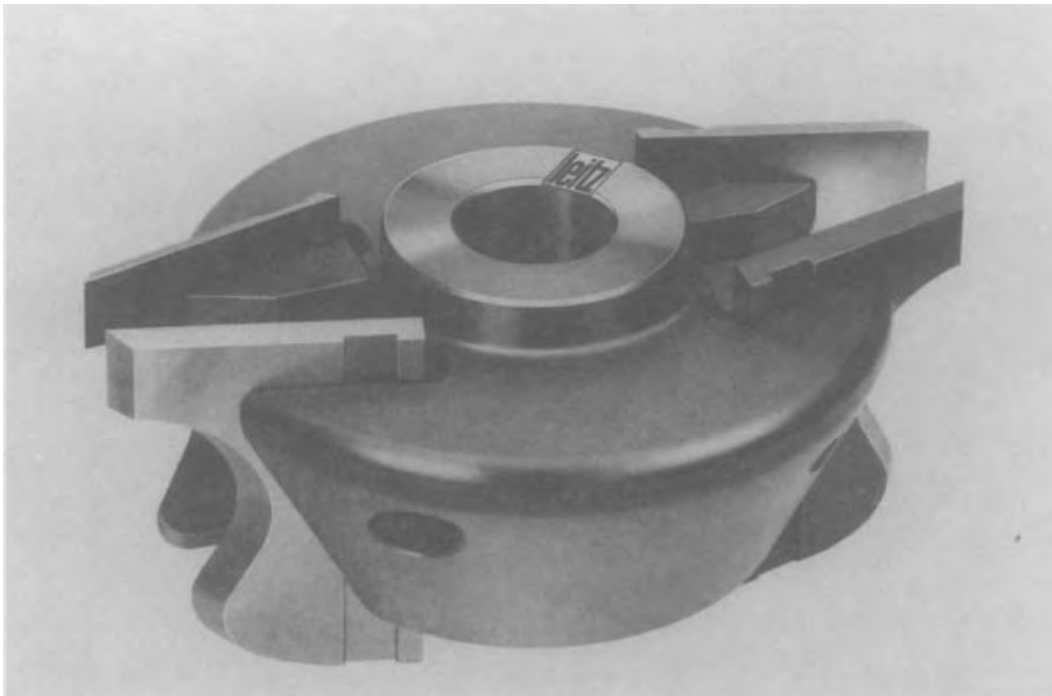

Photo 51: Profile cutter head with exchangeable knives



Technical design of spindle shaping machines

It is necessary to distinguish between the machines based on their application; primarily as to whether they are used for shaping straight or curved surfaces and edges (Table 36).

Table 36: Machines for shaping/moulding

Application	Machine
Shaping straight surfaces and edges	<ul style="list-style-type: none">• Double end tenoner
Shaping curved surfaces and edges (form shaping/moulding)	<ul style="list-style-type: none">• Spindle shaper/router with ring fence or copying pin and template• Mechanically controlled copy shaping machine• CNC router• CNC double end tenoner

The spindle shaper (Photo 52) represents the universal machine that can be used for shaping/moulding both straight and curved surfaces. The workpiece feed can be manual or by mechanical feeding devices. It is advantageous for the spindle shaper to be equipped with facilities for an inclined spindle position and for varying the revolution speed.

Photo 52: Spindle shaper/moulder

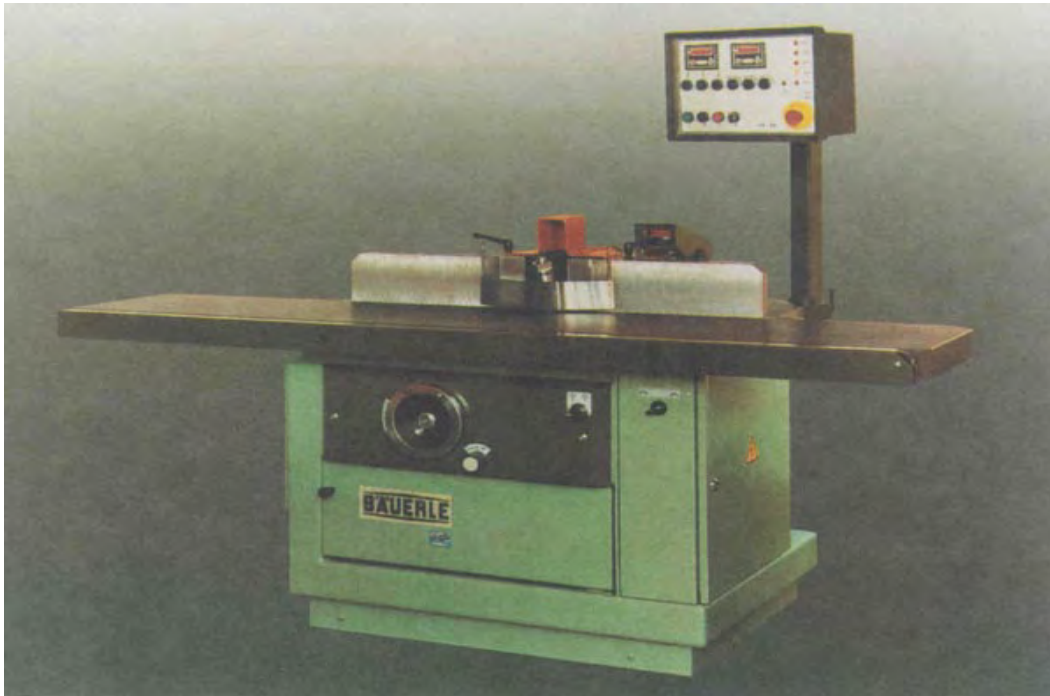

Fig. 86: Principle of copy-shaping with a copying pin and template

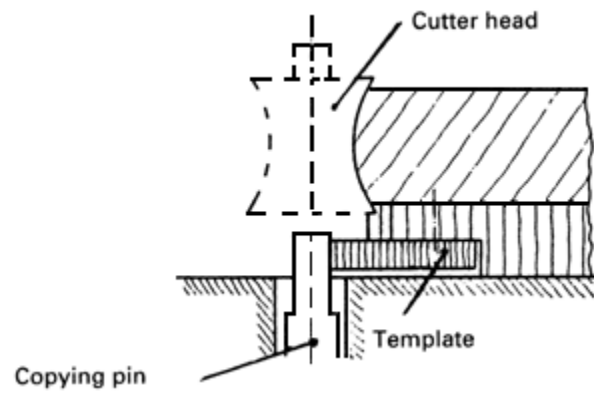
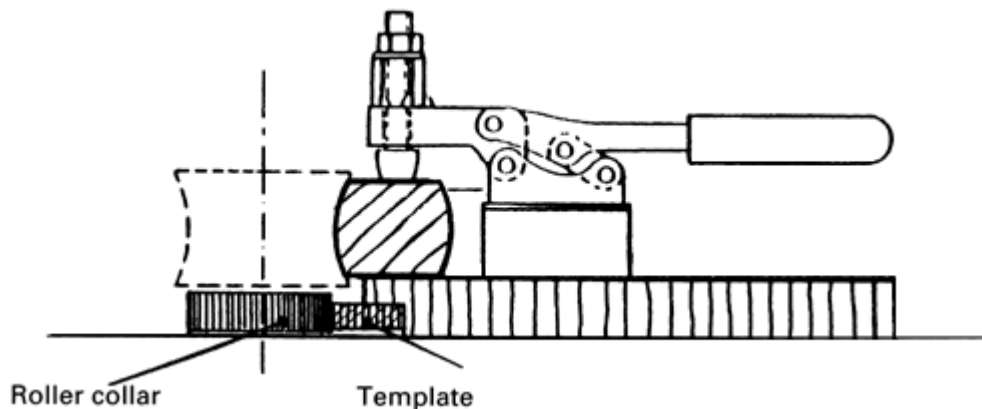

Fig. 87: Principle of copy-shaping with a roller collar and template



User information for shaping/moulding of coconut palm wood

Coconut palm wood turns out to cause problems in moulding because the resulting back-splintering and tearing are too great for use in furniture-making and in the area of visible wooden structural elements. This is true primarily for profile shapes with a large profile depth/chip removal volume. To achieve good surface quality a multi-stage machining method is recommended in order to reduce the chip removal volume and/or the cutting depth a_e per work cycle (see Figure 88):

Fig. 88: Multi-stage profile shaping

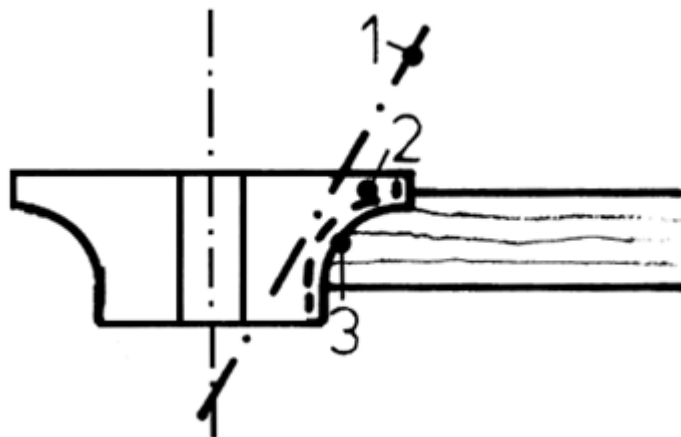

1. Oblique cut
2. Pre-moulding
3. Final moulding

Depending on the chip removal volume, very high cutting forces occur during moulding, which it is essential to take into account when selecting the tool, machine and template.

Because of the unsatisfactory surface quality, moulding at right angles to the grain should be avoided. This must already be taken into account during product development and design.

Torn edges of the kind that occur at the back edge of the workpiece when shaping at right angles to the grain can be avoided if counter-stops are used or if the splintering is included in the machining allowance (machining sequence: 1st cross shaping, 2nd lengthways shaping - see Figure 89).

Fig. 89: Operating sequence in shaping/moulding to avoid tearing of wood

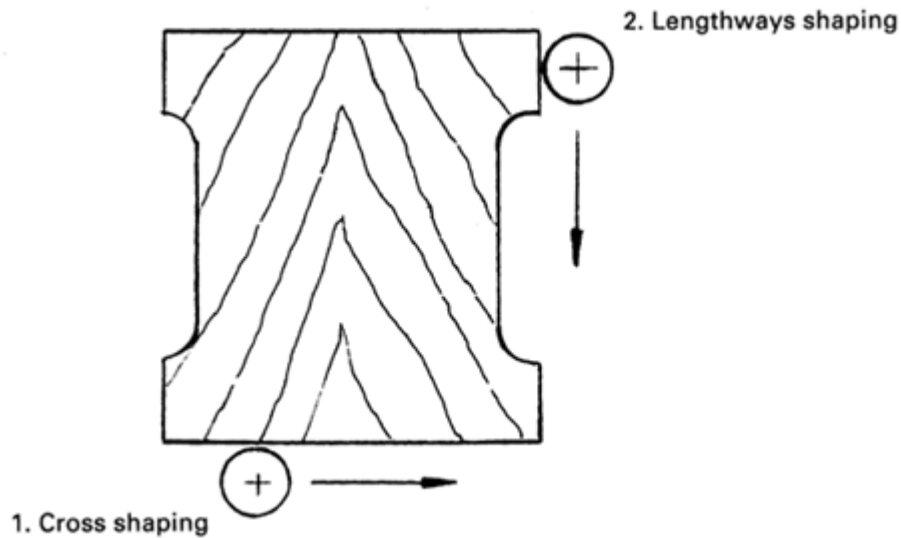

Cocos n. MD and HD show good to very good results when form shaping with TC cutting edges. This is true both for up-cutting and down-cutting (Figure 90).

Fig. 90: Form shaping

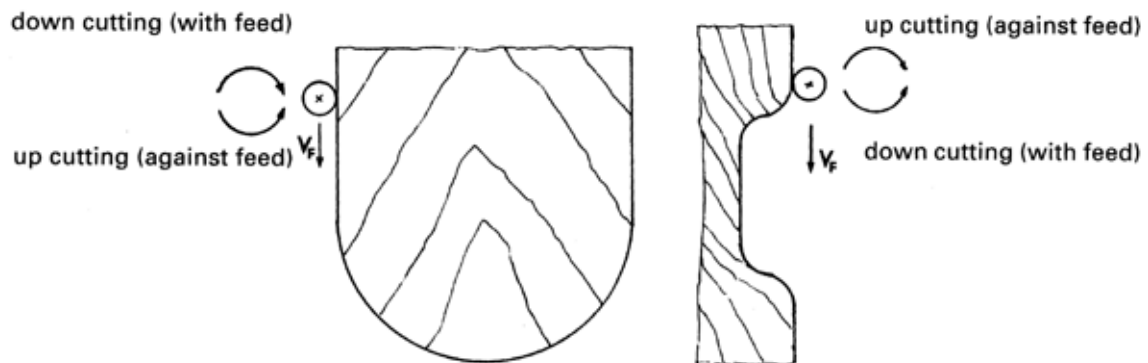

Large cutting forces can also occur during form shaping, depending on the chip removal volume. Multi-stage machining is advisable here again, and the contour of the workpiece should be pre-cut on a band-saw. Because of the cutting conditions, the highest cutting forces and poor surface qualities occur when cutting grooves with shank type cutters (Figure 91). Multi-stage machining (roughing, fine finishing) and/or single-knife/cutter tools can provide a remedy here.

Fig. 91: Groove shaping with a shank type cutter

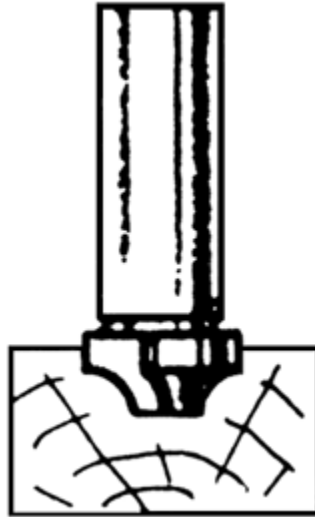

Table 37: Technical data for moulding

Feed per tooth f_z [mm]:	0.5.
Cutting speed V_c [m/s]:	40 - 60.
Cutting edge material:	TC, Stellite.
Cutting depth a_e :	as small as possible.

Table 38: Technical data for shaping

Feed per tooth f_z [mm]:	0.125.
Cutting speed V_c [m/s]:	10 - 30,
Cutting edge material:	TC.
Cutting depth a_e :	as small as possible.

Caution!!

Accident hazard

- Do not work in down-cutting mode with manual feed!
- Use only restricted chip thickness tools with manual feed!
- Very large cutting forces may occur (kick-back effect)!

Important

Profiles with large chip removal volumes must be multi-step machined!

8.6.5 End-face planing (hogging)

In end-face planing (see Figure 92), the tool axis is not perpendicular to the workpiece surface but is slightly inclined relative to it. The hollow surface resulting from this design has a vertex height that is negligibly small.

Fig. 92: Operating principle of end-face planing

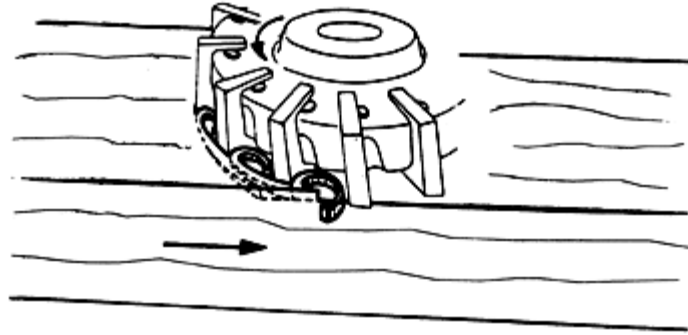

End-face planing can replace peripheral planing. Both methods aim at the same operational result, the "face planing" and "planing to thickness/width" of wide/narrow surfaces.

Technical constructions of end-face planing machines

End-face planing machines (see Photo 53) enable the machining of short work-pieces (min. 200 mm) without any additional clamping device. Basically two machine construction types can be distinguished based on the number and arrangement of the tooling:

- with several tools in a staggered arrangement relative to one another
- with one tool with a tool diameter corresponding to the working width {machines with a maximum working width of 2200 mm are available}.

Photo 53: End-face planing machine

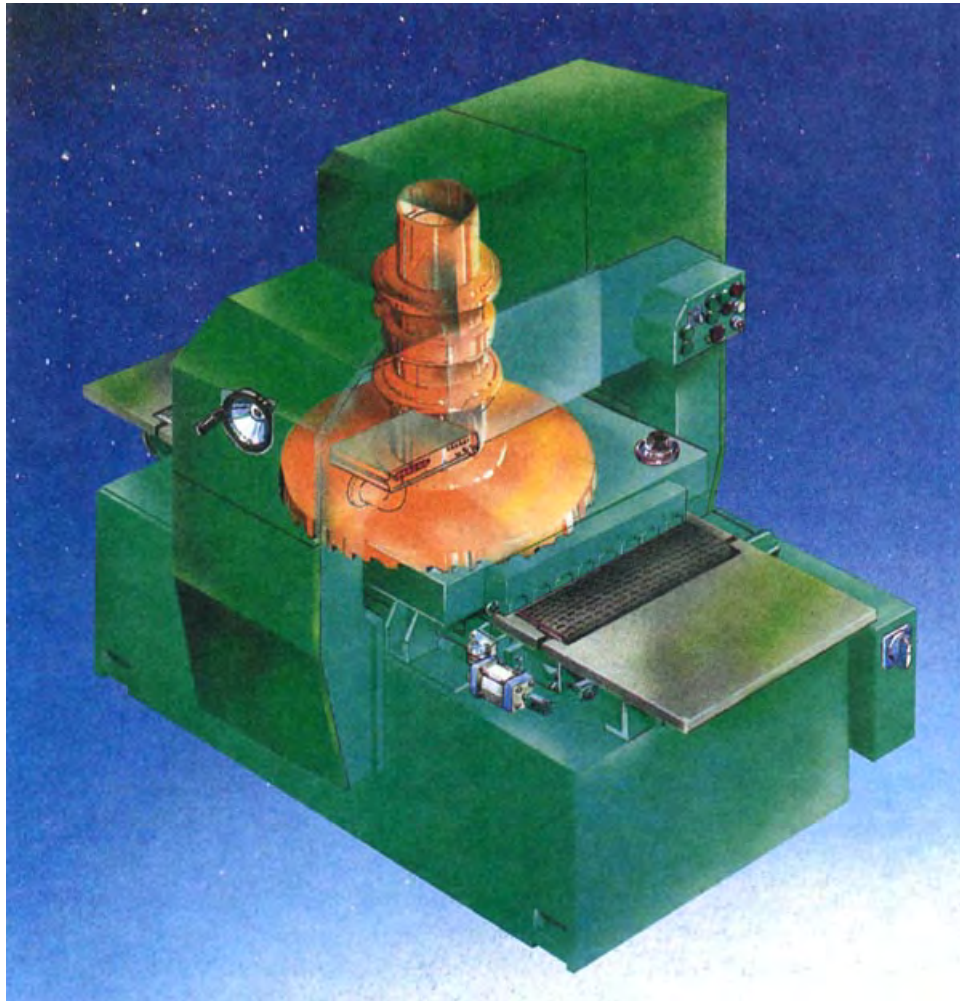

User information for end-face planing of coconut palm wood

Since end-face planing is a relatively "young" method in woodworking, it is not possible to report on a sufficient amount of practical experience. Laboratory tests with Cocosn. have shown good surface results that can be explained by the theory of end-face planing. For this reason no "Technical Data" is given here. It must be emphasized once again that end-face planing is applicable with good success particularly when machining coconut palm wood because of the chip-cutting principle.

One reason for this is that in contrast to peripheral planing, the vascular bundles are not "pulled" out of the tissue in a direction parallel to the machining direction but are sheared off sideways. Tearing out of the vascular bundles and also of the parenchyma (ragged edges) occurs at the point where the moulding cutter head leaves the workpiece as a result of the cutting movement at right angles to the fibre. This can be prevented by counter-stops strips and/or table constructions with in the planing machine (see Figure 93).

Fig. 93: Preventing ragged edges when end-face planing by a suitable counter-stop

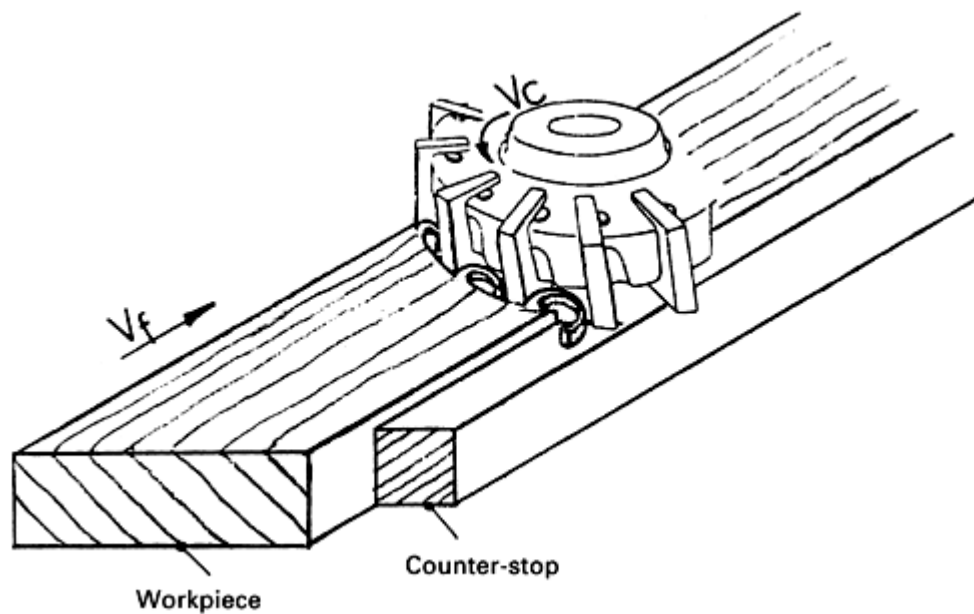

8.6.6 Boring

The operation of boring produces through holes or blind holes that are used to accommodate fasteners such as dowels or fittings (Figure 94). Boring represents the ideal technique for producing corner joints and joints for lamination of wood. The quality of the hole wall surface, hole entry edge and/or hole exit edge are critical, depending on the intended purpose of the hole. In this case the bit geometry and construction, and the appropriate workpiece-rest in the case of the exit edge, must be correctly constructed. This means that different bits should be used for blind and through holes to give good results (Figure 95).

Fig. 94: Operating principle of boring

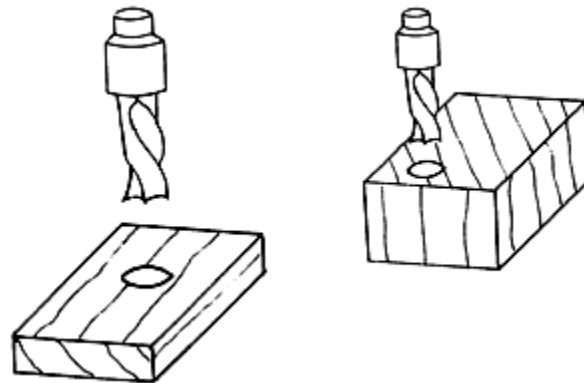
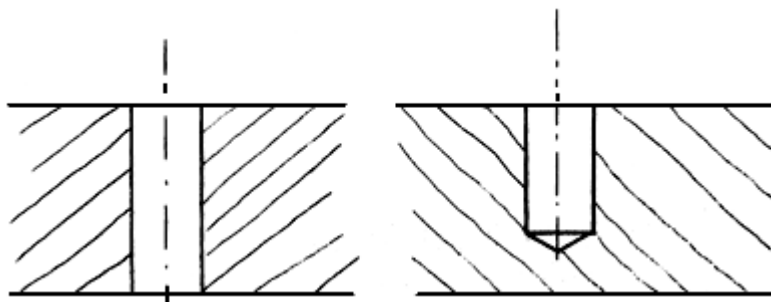

Fig. 95: Through hole (left), blind hole (right)



Technical construction of bits

Depending on the drill type, the wall surfaces of the drilled hole are formed by the main cutting edges (twist bit with roof-shaped point, mainly for through holes) or by the pre-cutting edges (dowel bit with lip and spur, mainly for boring blind holes). The danger of splintering occurs mainly at the entry and exit into/out of the work-piece. When boring into cross-grain wood, the main cutting edges each cut at right angles to the fibre.

In addition to the intended use (e.g. bits for dowel holes or countersink bits), bits are classified according to the shape and arrangement of the cutting edges (Figure 96).

Fig. 96: Twist bit (Ettelt, 1987)



Twist bit



**Dowel bit with centre brad point,
cutting lips and spurs**

Technical constructions of boring machines

There are many types of boring machines (see Photo 54). Boring sets are often integrated into multi-stage machines designed for other processes. A boring machine which has a swivellable boring head and which is therefore able to make horizontal and vertical holes can be regarded as the universal machine.

Photo 54: Boring machine with swivellable boring head



User information for boring of coconut palm wood

With Cocos n. MD and Cocos n. HD, boring can be used with good results for holes drilled both along the grain and across the grain. Splintering seldom occurs at the hole edge when boring.

The life span of TC bits is considerably longer than HSS bits. The fit of dowels pressed into the bored holes is good. Splintering of the kind that occurs at the bore exit edge can be avoided by appropriate workpiece rests.

8.6.7 Sanding

As a machining method, the purpose of sanding is to prepare surfaces with a specified shape and quality {Figure 97}. Sanding can be used to smooth surfaces and/or to produce a particular geometry, as in abrasive planing. In the first case sanding is used immediately before surface coating and in the second case abrasive planing can replace planing by cutter heads.

Fig. 97: Operating principle of sanding

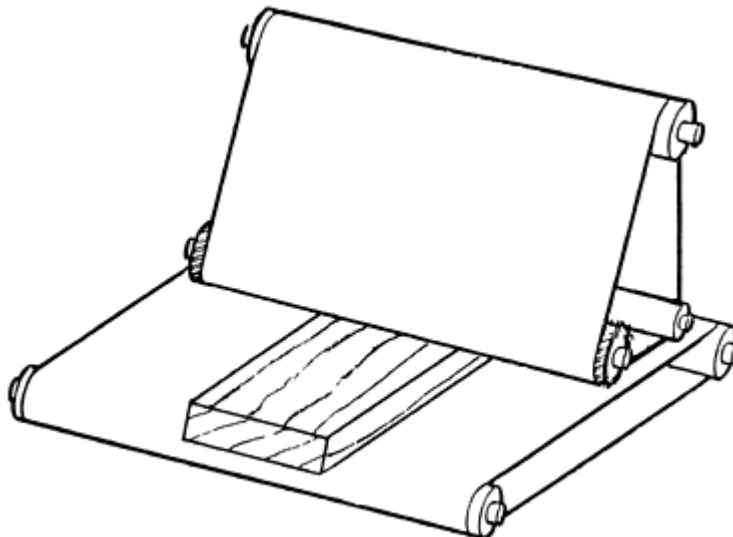

Technical construction of sanding tools

Sanding is a machining process with undefined cutting edge geometries (see Figure 98).

The material that is removed occurs as sanding dust. The cutting materials include aluminium oxide, silicon carbide, and, specifically for Cocos n., zirconia-alumina. These are glued to a backing material (paper, cloth) with phenolic resin. The cutting material is present as grit (granules). The grit is divided into sizes by sieving. The grit number gives the number of sieve meshes per inch. A grit value of 100 means that the grit has passed through a mesh which has 100 holes to the linear inch.

Fig. 98: Chip removal during sanding

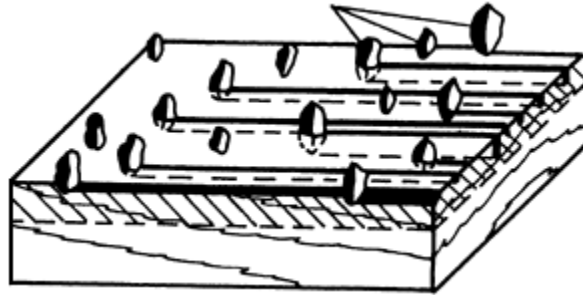

(Source: Argyropoulos, 1991)

Sanding belts (wide belt sanding machines) or sanding cylinders (cylinder sanding machine) are used to sand wide surfaces.

The following sanding tools are used for edge and profile sanding:

- Sanding belts
- Sanding disks
- Sanding drums
- Sanding straps
- Orbital sanding shoes
- Strip/brush sanding heads

All of the above-mentioned sanding tools for edge and profile sanding can be used for flat or profiled surfaces. The tool engagement zone must then have the corresponding required shape. Compared to other sanding tools mentioned, sanding belts have the advantage of a longer lifetime (exception: rather long sanding straps) because of the smaller engagement frequency of the individual sanding grit particle. Disadvantages with sanding belts are their restricted usability on complex profiles and the higher investment costs for the equipment.

An advantage of sanding disks (Photo 55) and sanding straps is that they can be used on simple machines, e.g. spindle shapers with revolution speed control.

Photo 55: Profile sanding tool

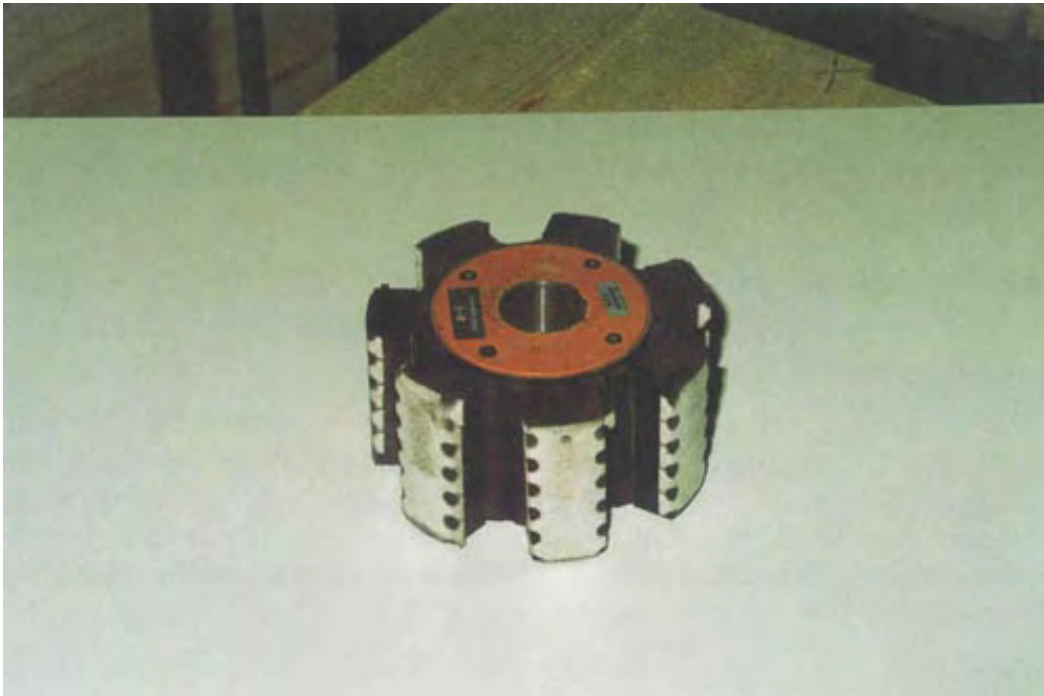

Technical construction of sanding machines

With regard to pre-conditions and results, there are considerable differences between the sanding directions along, across and perpendicular to the fibre (perpendicular to the end-grain). A rougher surface is obtained when sanding across the grain and a considerably higher amount of material is removed per unit of time (up to 100 %) than when sanding along the grain, under identical sanding conditions.

End-grain sanding requires sharp sanding belts, otherwise there is a danger of scorching the surface because of excessive friction and heat development without any chip removal.

The cutting speed when sanding is the same as the peripheral speed of the belt. When sanding solid wood the speed is between 20 and 40 m/s depending on the type of wood.

It may be beneficial to use the following work sequence, among others, when sanding wide faces of solid wood:

1. Sanding across the grain.
2. Sanding along the grain.

This combination is often used to achieve high-quality surfaces, since the first sanding pass (across the grain) shears off the fibres at the pore side edge and thus enables a better sanding quality. In addition, more material volume can be removed per unit time when sanding across the grain, as already mentioned. As a rule, the only additional thing that happens during the subsequent sanding along the grain is that the surface is freed from the transverse grooves left by the sanding grit of the cross-grain sanding, and is smoothed.

This principle can be implemented by several consecutive sanding operations and workpiece passes through one machine. However it can also be carried out in one workpiece pass by arranging the long and wide belt sanding units in a single machine, the cross-sanding machine.

User information for sanding coconut palm wood

For furniture-making requirements, 100 grit is adequate for Cocos n. HD as the last chip-cutting process before surface coating. For Cocos n. MD, 120 grit is needed.

The feed speeds on a wide belt sanding machine (Figure 99) should be set to 4 m/min for Cocos n. HD and 10 m/min for Cocos n. MD. When using wide belt sanding machines, flat engagement zones give slightly better operating results than cylindrical engagement zones, which show advantages at a high removal volume. Splintered-back and protruding fibres are sheared off well in flat sanding across the grain.

Fig. 99: Wide belt sanding set with pressure bar

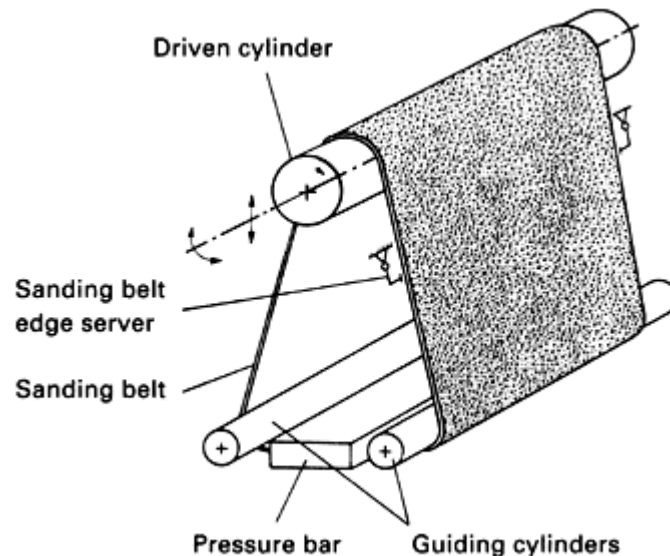

(Source: Argyropoulos, 1991)

Because of the small anatomical differences in a radial and tangential direction in Cocos n., all of the instructions also apply to the sanding of narrow surfaces. They can also be transferred to the use of profile belt sanding sets without any restrictions.

The life span of sanding belts with Cocos n.HD is small, especially under tropical climate conditions. A perfectly planed surface is advisable here, to save costs. Good sanding results with rather long life spans can be achieved at a small removal rate. Abrasive belts of the kind normally used for grinding metals also lead to longer life spans with Cocos n., and are being used successfully. In this case the abrasive particles consist of zirconia-alumina.

For sanding narrow surfaces at right angles to the grain Cocos n, HD shows well-sanded surfaces if the starting point, produced by the previous machining process, is already very good for this density class (cf. "Sawing-perpendicular to the grain" and "Shaping/moulding perpendicular to the grain"). The life span of the sanding tool in this direction of cut is small.

Splintering of the kind that occurs when sawing perpendicular to the grain and profile-milling perpendicular to the grain cannot be removed with an abrasive removal depth of 0.1 mm. The quality of the machining from the previous machining processes must be appropriately good if corresponding quality demands after fine finish machining are to be fulfilled.

Table 39: Technical data for sanding

Grit: Cocos n. HD:	100.
Grit: Cocos n. MD:	120.
Cutting speed V_c [m/s]:	20.
Cutting depth a_e :	as small as possible.

8.6.8 Mortising and tenoning

One of the commonest frame corner joints in woodworking is the mortise and tenon joint. Frame rails are divided across the thickness into an odd number of mortises and tenons. The joint is glued. The mortise and tenon joint has good strength values and is used both in furniture-making and in wooden structural elements (windows, doors).

Fig. 100: Operating principle of mortising and tenoning preceded by a dimensioning saw

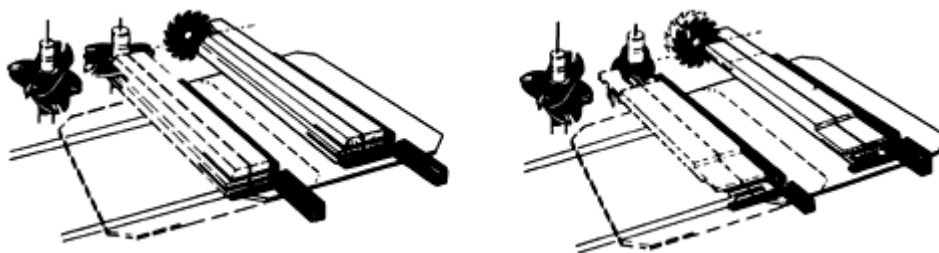

The frame rail is "cut perpendicular to the end-grain". The tools have a large cutting diameter because of the large cutting depth. Cutter blades whose cutting edge width corresponds to the mortise width are fixed to a relatively thin tool body (disk) by positive and frictional engagement. Because the chip removal volume is large and the fibre cutting direction affects the cutting edge angles, the cutting edges have a small sharpness angle and a large orthogonal clearance angle.

Table 40: Tool angles when mortising and tenoning coconut palm wood with TC blades

Wedge angle (°) β	Rake angle (°) γ	Clearance angle (°) α
55	10-15	>15

The workpieces on a rolling table are moved mechanically or manually. Splintering at the tool exit surface should be prevented by using counter-stops.

Alternatively circular saws can be used, especially to prepare tenons. The circular saw cuts for the tenon shoulders must be at right angles to the tenon surface.

User information for mortising and tenoning

With Cocos n. MD, the results of machining are characterized by smooth tenon surfaces with splintering in the region of the parenchyma, good fit and marked edge raggedness at the workpiece exit edges despite the use of counter-stops. Although the splintering scarcely has disadvantageous effects after glue-bonding the mortise and tenon, the ragged edges mentioned above can have entirely disadvantageous consequences, at least through the visual appearance in the area of the narrow surfaces of the glue-bonded components. This kind of splintering may be removed by outside profiling after glue-bonding (e.g. window frames), but this must not take place in all cases.

A pre-sawn tenon shoulder shows perfect work results, but the ragged edges at the long edges of the mortises and tenons still occur.

Cocos n. MD can be machined satisfactorily with tool designs corresponding to the standard design of medium-density woods. However, because of the existing wood properties and wood quality in the case of Cocos n. MD, widespread use of this wood for very high demands with regard to product and machining quality cannot be expected.

Cocos n. HD shows the following features: smooth wall surfaces without splintering of fibres and parenchyma, press-fitting because of the elastic bending deformation of the mortise disks as a result of high cutting forces and/or short-duration compacting of the wood tissue during the cutting operation, edge ragged ness in the side surface longitudinal edge region of the tenon/mortise at the tool exit side, and slight or no splintering with a sawn tenon shoulder.

In practice, in frame designs based on mortise/tenon jointing, splintering can often be set in the non-visible areas (inner side) or it can be removed by subsequent format machining or outside profiling.

It may be necessary to resort to alternative frame corner joints, e.g. the use of dowels. The "boring" process used to prepare the dowel holes for this is feasible with very good results with all grain directions/feed directions.

A further point that should be mentioned about mortising and tenoning is that exceptionally large cutting forces occur with Cocos n. HD, that cause very strong vibrations of the woodworking machine (= high stress on bearings, guides etc.), and that very short tool/cutting edge life spans were recorded. In the event that spindle shapers with built-in sliding/rolling tables for mortise and tenon cutting are used, the machines and table structures must be of very solid construction.

Table 41: Technical data for mortise and tenon cutting with slot and tenon cutters

Feed per tooth f_z [mm]:	0,01-0,025.
Cutting speed V_c [m/s]:	20.
Cutting edge material:	TC (HSS is possible in some cases).

8.6.9 Dovetailing

Finger dovetailing is often used as a corner joint, mainly to join solid wood components together (Photo 56). Board surfaces are given equally spaced dovetails by cutting. The joint is glued and must be of high quality since it is often used in a visible position.

Photo 56: Operating principle of dovetailing

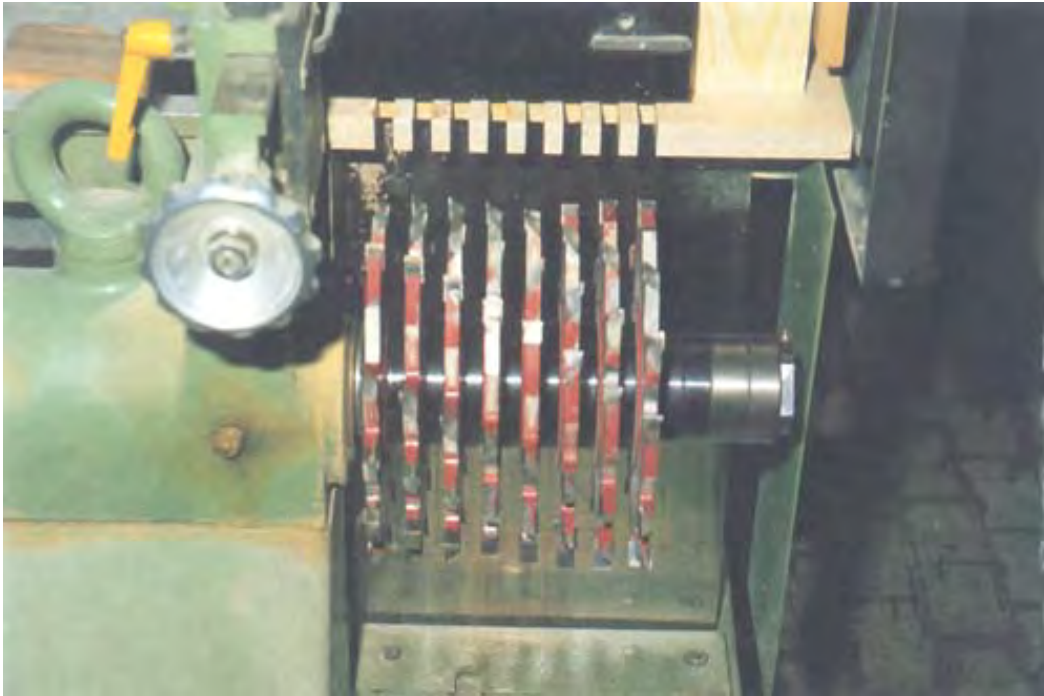

The special fibre cut direction and the requirements applying to the fit and quality of the cut surfaces demands tools with main and spurs cutting edges that are designed for this specific case.

Transverse profile cutting machines with mechanical feed are used in industrial applications, otherwise spindle shapers are also used. The use of counter-woods at the tool exit should prevent splintering.

User information for dovetailing

The result of the operation is good to very good when TC cutting edges and counter-stops are used in the dovetail cutting process.

Cocos n. MD shows splintering at the longitudinal edges of the dovetails (tears) but the inner surfaces and the dovetail base are smooth and the fit is good. Cocos n. HD shows smooth inner surfaces and a splinter-free dovetail base with no ragged edges. One special feature that must be mentioned is the extreme tight fit of all of the dovetail components, which is very pronounced in spite of an identical machine/tool setting. This feature already occurs with newly-sharpened tools and it is very probably attributable to three causes:

1. The high density wood tissue opposes a large resistance to the cutting edges, the vascular bundles present in rather large numbers are pressed into the "softer" parenchyma from which they spring back again after the cutting process, and an elastic deformation of the tissue occurs.
2. The lateral cutting edges of the cutting tools deflect sideways because of the large cutting forces, altering the geometry. These deflections are in a range between 0.01 mm and 0.02 mm, too small to be registered with common measuring tools.
3. Because of the high density, the dovetail cheeks do not compact when pressing together the joint components to the same extent as, for example, with woods of lower density.

This tight fit requires corresponding corrections in the machine adjustment and tool setting and/or construction. In addition special precautions are needed in the machine design and workpiece clamping because of the very high cutting forces with Cocos n. HD.

Finger joints of the kind used for the length and width jointing of solid wood are a problem with coconut palm wood because the tips of the cutting tool taper to zero and the wood tissue does not have sufficient strength. The parenchyma breaks out during machining and produces ragged cut edges and points, and the fibres protrude and prevent the profiled components from coming close together. The cutter tips also wear away very quickly.

Finger joints should be avoided with coconut palm wood (in this connection see also Chapter 2).

8.6.10 Swing chisel mortising

Swing chisel mortising produces openings in the wood (mortise holes), as a rule with rectangular cross-sections.

Fig. 101: Operating principle of swing chisel mortising

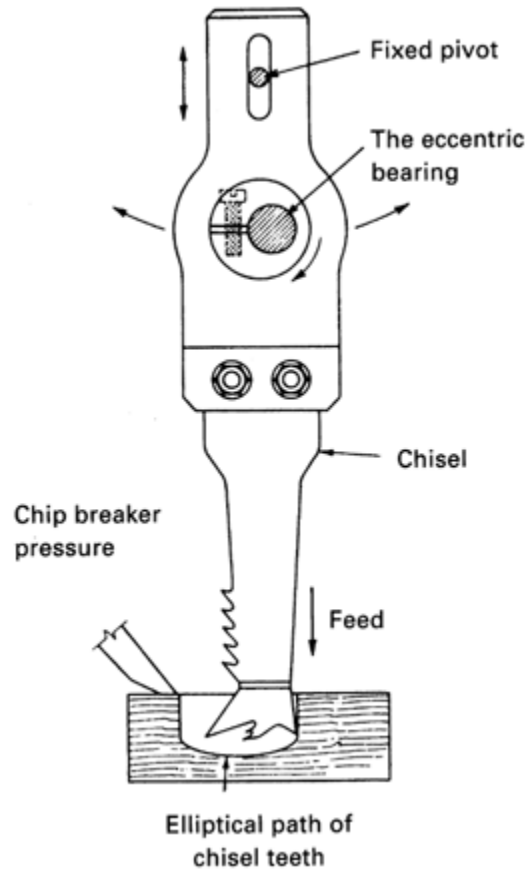

Source: Sherlock, 1991

For this purpose it is possible to use two known systems that differ in their tool construction and cutting kinematics. One system uses a three-part tool consisting of two lateral mortising chisels that oscillate linearly up and down, and one central chisel with two cutting edges that oscillates around a pivot and cleans out the opening (see Figure 102).

Fig. 102: Three-part swing chisel mortising tool

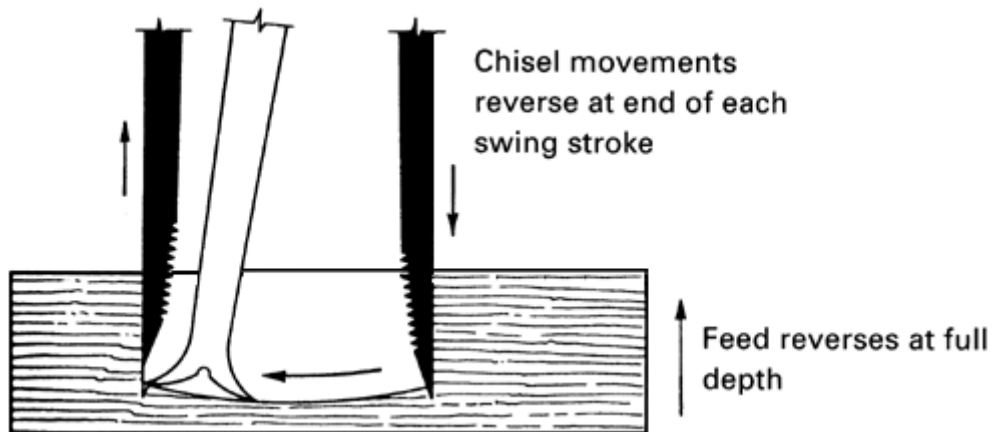

Source: Sherlock, 1991

The other system uses a single-part, toothed tool that moves in an oscillating path (Figures 101,103). The tool is moved by an eccentric and is guided in a straight slot at the top. This causes an elliptical cutting edge movement. Slightly rounded-off teeth, whose function is to carry the chipped material out of the opening, are ground onto the front edge of the tool where the chips produced by the lower cutting edge arise. The actual chip-cutting process is similar to shaping, taking into account the oscillating tool movement and the non-constant cutting speed. The cutting speed is at a maximum at the centre of the oscillation and at a minimum at the two tool reversal points.

At the tooth exit side the edge fibres of the workpiece must be supported by a hold-down device, also called a chip-breaker, since otherwise splinters occur at this area of the workpiece. The tool cutting edges have lip clearance angles at the sides to prevent the teeth from scraping on the walls of the opening.

As a rule, oscillating chisel tools are made from HSS steel, but can also be constructed with TC tips.

Fig. 103: Construction and principle of the single-part oscillating chisel mortising tool

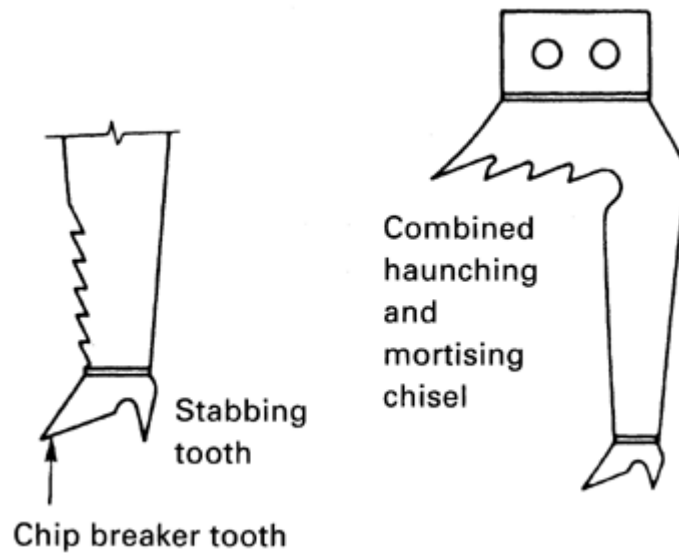

Source: Sherlock, 1991

User information for swing chisel mortising

Swing chisel mortising achieves good to very good work results with splinter-free hole walls and edges. The feed speed that is used depends on the density. The cutting forces with Cocos n. HD can be described as exceptionally large, and the tools also blunt very quickly. Because the relative cutting movement differs from mortising and tenoning, the work results that are achievable when using a standard tool with coconut palm wood are considerably better than in tenon mortising. TC-tipped oscillating chisels that are processed for special individual cases can achieve rather long lifetimes. Care must be taken to use a particularly heavy machine construction and good workpiece clamping when chisel mortising Cocos n. HD.

8.6.11 Lathe-turning

Cylindrically smooth and profiled workpieces can be produced by lathe-turning (Figure 104). Because of the wood structure and relative cutting direction in turning, highly profiled geometries with profiles tapering to a point should be avoided with coconut palm wood (in this connection see also Chapter 2 "Products and Design").

Fig. 104: Operating principle of straight (plain) lathe-turning

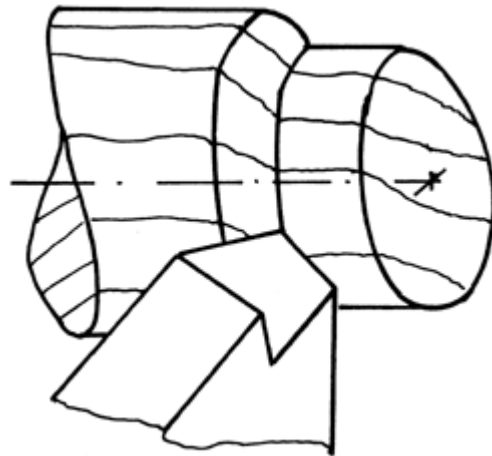

Technical construction of lathe tools

The machining process of turning produces rotationally-symmetrical workpieces by a circular cutting movement of the workpiece. The tool carries out the forward feed and adjustment movements. As a rule in this method the chip runs on the top cutting surface of the workpiece, chip removal taking place at the periphery of the workpiece.

The following remarks refer to machine designs in which the tool movement is mechanical (no manual tool guidance and movement). The tools used include lathe chisels of various designs and profiling cutters. The latter have the shape of the turned (work) surface that is to be produced and are inserted at right angles to the rotation axis (Figure 105).

HSS steels and in some cases tungsten carbide (TC) are used as the cutting edge materials. HSS and TC tools are only tipped with these cutting edge construction materials, the shafts then consisting of structural steel or other low-alloy manganese steels.

The cutter tip is at the same height as the axis of the rotating object. If the forward feed direction is parallel to the rotation axis, this is called long turning. The main cut direction is parallel to the fibre (grain) direction and the secondary cut direction is at right angles to the fibre direction.

The lathe chisel can be tipped with a bell-shaped knife (Figure 106) or cutting cylinder (circular cutting edge). In addition to the advantage of a relatively large cutting curve to achieve very small roughness depths, this cutting cylinder has the additional benefit that the entire cutting edge periphery can come into use by sequential turning of the cutting cylinder after a used position has been blunted. For the reasons mentioned above, this cutting edge shape has proved to be very good in the present case with coconut palm wood.

Fig. 105: Cutting angles and edges on lathe chisels

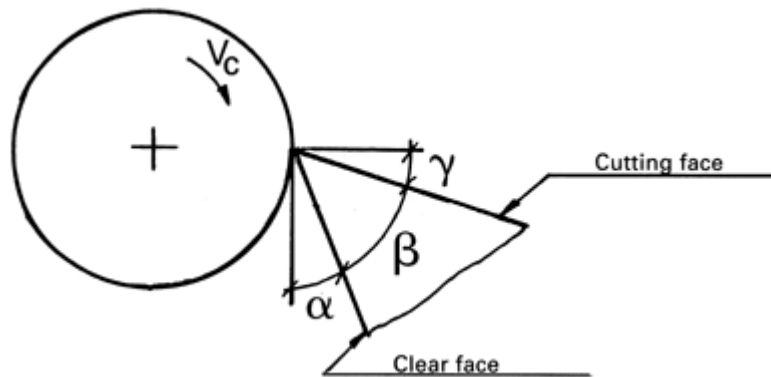

- α = clearance angle
- β = wedge angle
- γ = rake angle
- V_c = cutting/rim speed

Fig. 106: Diagram of the principle of a bell-shaped knife

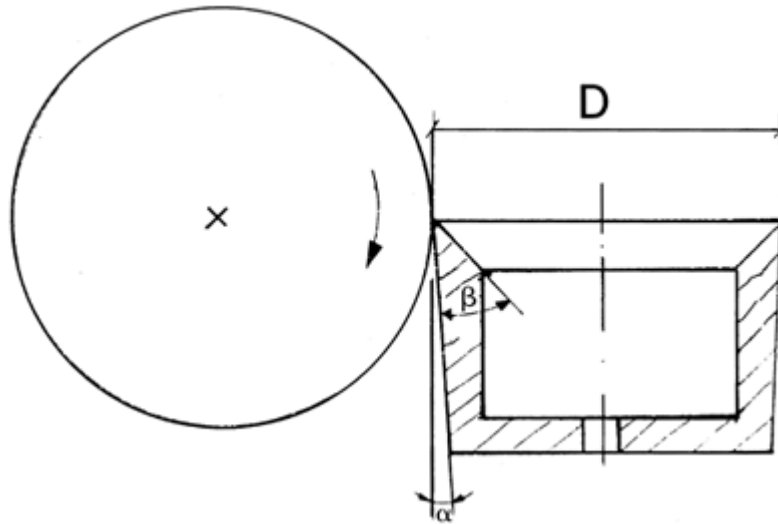

User information for lathe-turning

Cocos n. MD shows break-outs in the parenchyma and severe back-splintering as the cutting edge bluntness increases.

Cocos n. HD shows good work results with only a slight tendency to break-outs and back-splintering.

As a result of the relative direction of cutting that occurs in longitudinal turning, long lifetimes are achieved by the favourable chip-cutting conditions. Lathe chisel cutting edges tapering to a point, as are used when turning conventional wood species, give bad results with coconut palm wood. This manifests itself as grooving and torn-out vascular bundles.

The cutting speeds in wood-turning are in the range from 1.0 m/s to 12 m/s and depend very greatly on the type of wood, among other things, and in the present case especially on the density. The cutting tool tip (lance) should always have a certain radius and for the reasons mentioned above it should not taper to a point.

Table 42: Technical data for (straight) longitudinal turning

Cutting speed V_c [m/s]:	2.
Cutting tool material:	HSS (bell-shaped knife).
Cutting depth a_e :	as small as possible {multi-step process if large volumes are to be machined away}.

8.7 Gluing technique

It is often necessary to use a gluing (glue-bonding) technique, e.g. to manufacture wooden joints such as dowelled joints, mortise and tenon joints etc. and to obtain larger thickness, width and length dimensions. Because of the density distribution in the coconut palmtree trunk and the resulting cutting patterns, the maximum cross-section dimensions that are achieved from one density region are about 100 x 50 mm (4" x 2"). Glue-bonded wood structures are used both in furniture construction and in wooden building components. Typical examples in the latter area include laminated window scantlings and laminated beams. A combination of palm wood with plywood to manufacture box beams or I-beams has already proved successful in several applications, e.g. in construction buildings in Zamboanga and Davao in the Philippines (see Chapter 2.2, Design - glue-bonded construction material).

Basically all types of glue designed for gluing wood can be used to glue coconut palm wood, e.g. PVA adhesive, urea, melamine and phenol-formaldehyde adhesives, as well as epoxide and polyurethane adhesives. The choice of adhesive depends mainly on the conditions of use {interior/exterior use, climate resistance) and on the machining conditions (joint gluing, assembly gluing, fitting tolerance of the components, wood moisture content etc.). In principle it can be stated that coconut wood has a very good gluability.

Pre-conditions for gluing Cocos n.

- The wood must be dried to the final wood moisture content corresponding to the subsequent application climate.
- The surfaces that are to be glue-bonded must be smooth and dust-free and there must be no vascular bundles projecting from the surface, as they impede the required joint fit.
- Wood joints must be machined to an accurate fit and must have sufficiently large adhesion surfaces appropriate to the joint strength requirements (e.g. dowels versus double mortise and tenon).
- An adequate amount of glue must be applied. The basic parenchymatic tissue of coconut palm wood has a high absorbency that takes up the adhesive rapidly and thus leads to a starved glue line. This effect occurs especially with cross-grain wood surfaces and with Cocos n. LD. Remedies include high-viscosity adhesives (based on PVA) or a double application of adhesive to these critical surfaces.
Note: Dowel holes may have a high proportion of cross-grain surfaces.
- It is essential that adhesives are stored, prepared and used in accordance with the adhesive manufacturer's instructions. This applies particularly to the open time at elevated ambient temperatures, which is critical and leads to defective gluing if it is exceeded.

Special instructions regarding the technique for glue-bonding Cocos n.

The use of glue-bonded profiles for full-width glue-bonding (Figure 107) may have advantages in certain applications (strength, reduction of thickness misalignment etc.). Care should be taken to ensure that glue-bonded profiles do not taper to a point since otherwise there may be machining problems and less accurate fits as a result of projecting vascular bundles. For this reason finger joints are not recommended.

Fig. 107: Design of glue-bonded profiles

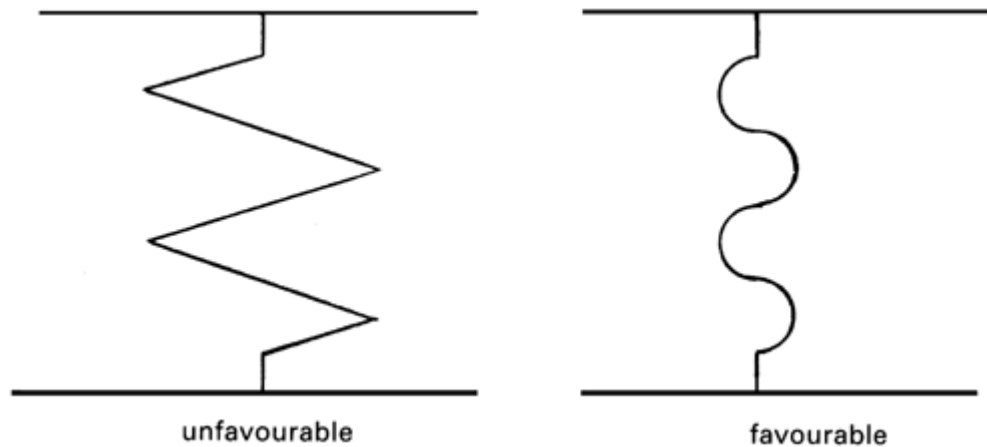

It is entirely possible for the various layers to have different densities when manufacturing laminated scantlings and boards made of multiple layers, for example glued together in thickness. Thus in three-layer panels the facing layers can be made of Cocos n. HD and the core layer of Cocos n. MD. In contrast to conventional wood species, this does not cause any problems resulting from dissimilar shrinkage and swelling behaviour. This varies only slightly for coconut palm wood of different densities. This must be seen as a great advantage for the economic use of coconut wood, since the yield factor can be improved considerably as a result of the ability to use medium and low density wood.

Important

- No vascular bundles protruding from the glued surface!
- Application of sufficient adhesive, especially in cross-grain regions and with Cocos n. LD (two-sided or multiple glue spread)!

Caution!!

- It is essential to obey the adhesive manufacturer's instructions when storing, preparing and using adhesives!
- It is essential to avoid effects on the environment and on the employees when using adhesives, and the same also applies to the disposal of adhesive residues. Some adhesives are classified as dangerous substances!

8.8 The finishing of coconut palm wood

Finishing is one of the last manufacturing operations in interior completion and in furniture-making. Its main purpose is to protect the wood surface against environmental effects and it is a method for decorative finishing and for enhancing the utility of the product. Specific instructions for the surface treatment of coconut palm wood are given below.

The sequence of operations is as follows:

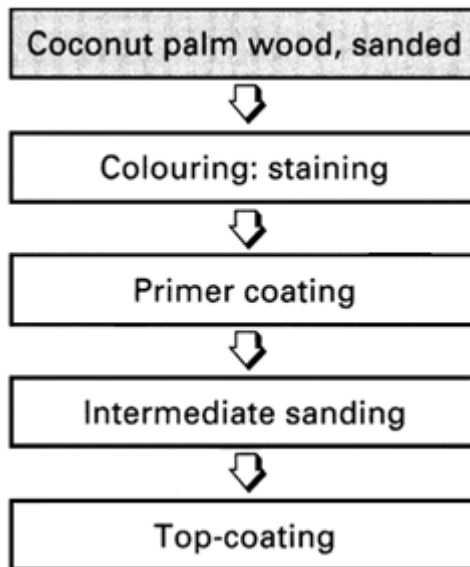

User information for the machining process of coconut palm wood Sanding

A well-sanded wood surface is a pre-condition for high surface quality. The fine sanding of Cocos n. should be carried out with 100/120 grit, parallel to the grain and at a low pressure (see also Chapter 8.6.7).

Staining

Stains are materials for changing the colour shade of the wood. Their purpose is to equalize the colour, to emphasize the grain structure and to modify the colour shade. Stains consist of soluble dyes, pigments, chemical reactants, solvents and additives. The main types that are used are water stains and solvent stains (organic solvents). Quick-drying solvent stains are especially suitable for use in continuous processes. In contrast to the environmentally friendly water stains, they do not roughen the wood (do not raise the grain).

The batch of stain should be mixed according to the maker's instructions. A trial staining will reveal the true colour shade. Equipment containing iron (steel, ferrous metals) should be avoided when staining because it causes colour shade variations. Cross-grain surfaces and drilled holes/grooves absorb a larger amount of stain and have a darker appearance after drying. Cross-grain surfaces benefit from being wetted beforehand. If necessary, pre-stain and cover up drilled holes and grooves.

Cocos n. absorbs stain very well. The variations in the colour of the wood of the kind that often occur with Cocos n. can be evened out very well by staining. Because of its properties, the parenchyma absorbs the stain more strongly during staining than the vascular bundles, which leads to a negative staining pattern in the case of very dark stain shades, i.e. the vascular bundles appear paler than the parenchyma.

Prime and top coating

The prime and top coating of Cocos n. MD can give problems if the coating material is not properly formulated, because the parenchymatic tissue is softer than the fully cured/hardened coat layer. In the event of a mechanical stress (e.g. fingernail pressure), the brittle coat cracks or "whitens" because of the soft substrate. This effect can be avoided by using elastically formulated PU (polyurethane) paints. Fibres raise up after application of the prime coat, especially with water-based materials, and must be removed by intermediate sanding.

Basically it is true to say that coconut palm wood can be treated with all of the finishing systems that are suitable for finishing painting wood, provided that the material is formulated "elastically".

Caution!!	
•	Some surface-coating materials are dangerous substances. It is essential that the manufacturer's instructions are obeyed when handling and storing these materials (fire, explosion and occupational protection)!
•	It is absolutely essential to avoid effects on the environment and on the workpeople when using surface coating materials of all kinds. This applies especially to their application and disposal!

Oiling/Waxing

Cocos n. can also be treated successfully with synthetic or natural oils and waxes. In a combined treatment, dissimilar materials must be matched to the substrate, i.e. to the density of the specific palm wood and to each other. The parenchyma is particularly absorbent when using oil or glaze. When using wax it may in some situations be necessary to refrain from using oil previously. Greying of the surface may occur if the above instructions are not obeyed.

Important

- All of the applied materials (stain - pore-filler - primer - top-coat paint) must be matched to one another!
- Because of compatibility with one another, coating materials from a single manufacturer must be used!
- Laequer does not provide durable wood protection for coconut palm wood that is used out of doors!

8.9 Summary of machining conditions for the important cutting methods for coconut palm wood

The technical data for the important machining processes when working with coconut palm wood are summarized in this chapter to enable a quick overview and access.

Table 43: Sawing - Parallel and perpendicular to the grain in Cocos n.

Feed per tooth f_z (mm):	0.05-0.1.
Cutting speed V_c (m/s):	60 - 90.
Cutting edge material:	TC, Stellite.

Table 44: Narrow band-sawing

Cutting speed V_c [m/s]:	ca. 30.
Cutting edge material:	CN-hardened, Stellite.

Table 45: Planing

Feed per tooth f_z [m/s]:	0.5-1.
Cutting speed V_c [m/s]:	ca. 40.
Cutting edge material:	TC.
Cutting depth a_e :	as small as possible.

Table 46: Moulding/profiling

Feed per tooth f_z [m/s]:	0.5;
Cutting speed V_c [m/s]:	40 - 60.
Cutting edge material:	TC, Stellite.
Cutting depth a_e :	as small as possible.

Table 47: Shaping/moulding

Feed per tooth f_z [m/s]:	0.125.
Cutting speed V_c [m/s]:	10 - 30.
Cutting edge material:	TC.
Cutting depth a_e :	as small as possible.

Table 48: Sanding

Grit: Cocos n. HD:	100.
Grit: Cocos n. MD:	120.
Cutting speed V_c [m/s]:	20.
Cutting depth a_e :	as small as possible.

Table 49: Mortising and tenoning with slot and tenon cutters

Feed per tooth f_z [m/s]:	0.01-0.025.
Cutting speed V_c [m/s]:	20.
Cutting edge material:	TC (HSS is possible in exceptional cases).

Table 50: Straight lathe-turning

Cutting speed V_c [m/s]:	2.
Cutting edge material:	HSS (bell-shaped cutting knife).
Cutting depth a_e :	as small as possible (multi-stage operation for rather large chip removal volumes).

8.10 Sequence to determine the machining conditions

The sorting of Cocos n. into density ranges (see Chapter 5) is an essential precondition for the use of optimum machining conditions that are matched to the raw density class.

In addition, before processing cut timber consisting of Cocos n., the intended use/application should be known exactly, since the machining conditions must also be matched to this. The following sequence diagram shows the procedure for using and machining coconut palm wood, starting with unsorted cut timber and leading to the carrying out of the individual machining stages.

**Sawn timber of Cocos n.
of mixed raw densities**



Sorting by
- density (class)
- defects
- colour etc.



Defining the
intended use/application
and the
required output (net) volume



Defining the
processing methods
for each processing step up to
the required level of production



Selection of the
- machines
- tools
- process parameters
- machining qualities
for each process



Selection and provision of
sawn timber according to
- raw density
- wood quality
- colour
- equired gross volume



Machining of the sawn timber
in several steps

9 Energy from coconut wood

The range of densities and moisture content within the stem of the coconut palm also influence its utilization as fuelwood or charcoal. Usually, the husks are preferred as fuel, and the shells for charcoal production. Due to their high density, coconut shells yield a high class charcoal. This charcoal is even exported to Japan for the manufacture of activated carbon.

9.1 Firewood

The stem can be converted into firewood by cross-cutting and splitting it into billets of about 30 cm length. These billets have to be seasoned before burning. While the lower, outer part of the stem yields good firewood, the upper portion and particularly the upper core will only find a use as firewood where no other fuel is available. Seasoning takes too long, and the timber degrades rapidly when seasoned in billet-form. The slabs and offcuts of the lower stem portion can be used for generation of thermal energy, e.g. for heating a seasoning kiln. Sawdust, when compressed in an old can and with a center bore provided, renders good fuel for cooking. The can as such can be used as a stove. The burning time depends on the can size.

9.2 Charcoal

As mentioned earlier, in most cases coconut wood charcoal has to compete with that of the coconut shells, and there usually loses out for nearly any reason but that of bulk. There exists an abundance of charcoal kiln designs. For coconut wood, the portable charcoal metal kiln mark V designed by the Tropical Products Institute, London, UK, has proved successful (Photo 57, Figure 108).

Photo 57: Charcoal kiln "mark V"



Fig. 108: Charcoal kiln "markV"

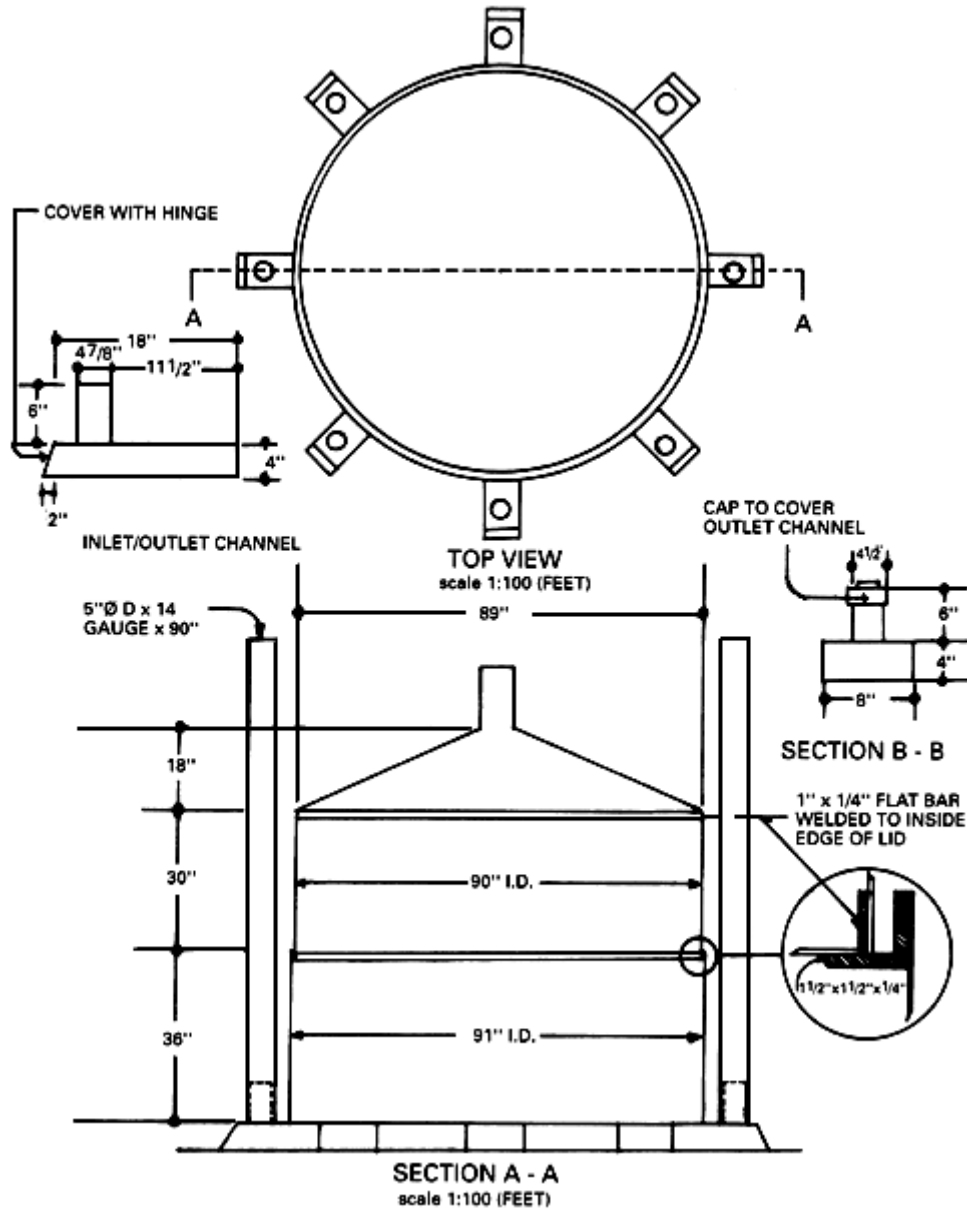

Description

The kiln consists of two interlocking cylindrical sections. The bottom section is made from 14 gauge mild steel, 2.30 m in diameter and 0.9 m high. The second section is made from 16 gauge mild steel, 2.25 m in diameter and 0.75 m high. Its conical cover is also made from 16 gauge mild steel. The kiln rests upon eight 0.10 x 0.20 m box section channels, each about 0.5 m long with closable vents and collars. It has four metal smoke stacks 0.13m in diameter and 2.25 m high. The kiln has a capacity of 8.6 m³ of wood. Advantages besides its good performance are that it easily can be manufactured locally, and that it can be disassembled and transported. If properly maintained, the kiln can last up to five years.

Production

The timber should be cut short, split into billets and seasoned before loading the kiln. Carbonization time can be reduced by using coconut wood with a moisture content below 30%. Assembly and loading the kiln takes two hours for two men. Lighting is done from the top in order to facilitate control and to increase production. Lighting and carbonization require an average of 20 hours, cooling time another 18 hours. Two men can unload the kiln in two hours. The kiln yields an average of 400 kg coconut wood charcoal per charge with a recovery of 21 %.

The chemical analysis of the charcoal has shown (Palomar, 1981):

- moisture content	13%
- volatile combustible	14%
- ash content	3%
- fixed content	70%

The high amount of powdered charcoal produced can be converted into briquettes. Briquetting is dependent on availability and costs of starch as a binder. Any locally available starch will do. It should be applied at about 5-10% by weight.

10 Economics

10.1 Profitability

Every business managed as a private enterprise is compelled to trade according to the principles of economics and to make a profit in order to remain competitive and viable. This profit is needed to finance:

- Withdrawals (entrepreneur's remuneration)
- Capital investments
- Payment of interest on capital
- Repayment of credits
- Reserves
- Taxes on profits

The profit is also affected by the company's performance and thus depends on the following parameters:

- Income (Market price of the products)
- Material usage (Material costs)
- Wages and salaries costs
- Miscellaneous fixed and variable costs

Thus profit is achieved not solely by increasing income, since for example the sales volumes and product prices in the market cannot be increased at will, but also by reducing the other costs mentioned above, whose total constitutes the manufacturing costs. These costs must be planned, controlled and monitored in the context of a profit-oriented business management to enable the planned profit target to be achieved within a period of time under review. The determination of the manufacturing costs for a given product or group of products is carried out in the context of the costs calculation and will be discussed in Section 10.1, taking cut timber from coconut wood as an example.

Since absolute values are not very relevant, the important thing is the profit in relation to particular parameters such as the capital employed or the turnover achieved.

The ratio based on these parameters is called the profitability {Figure 109):

Fig. 109: Profitability

$$\text{Profitability} = \frac{\text{Profit}}{\text{Capital employed}} \times 100$$
$$\text{Turnover profitability} = \frac{\text{Profit}}{\text{Turnover}} \times 100$$

When deciding whether or not to carry out a capital investment project, the main thing of interest is how and how successfully the capital that is employed will return again and whether it will be necessary to employ additional capital, e.g. at the start of the project's life, to cover initial losses. Profitability calculations are used to plan and assess capital investment projects. Profitability calculations for capital investments consist of a comparison between the expenditures for investments and for the on-going operation of the investment project (= costs), and the expected income (= proceeds) that are to be achieved through the capital investment project. The comparison of incomes and expenditures is carried out for several periods of time, the surplus (= cash-flow) of proceeds over expenditures being determined for each planning period. The profitability of the capital investment is calculated on the basis of the income surplus.

Table 51: Model of a cash-flow analysis

Period1	Period 2	Period 3	Period n
I.	Outgoing payments for investments		
II.	Planned payments for manufacturing of goods and services (manufacturing costs)		
III.	Cash-outflow (I + II)		
IV.	Cash-inflow (Revenues)		
V.	Cash-flow (IV ./ III)		
VI.	Cumulated cash-flow - Period 1- n		
Result: Profitability, e.g. Internal Rate of Return (IRR)			

One measure of profitability is the "Internal Rate of Return", which expresses how the capital employed is bearing interest. A detailed explanation of the determination of the internal rate of return must be left to the specialist business economics literature. The advantage of the "internal rate of return method" is that it eliminates the time difference between the payment dates for the investments and the return flows (pay-offs) of capital in the individual periods of the project lifetime by discounting the interest amounts to the start of the planning period (= cash value). This is especially relevant to the result when periods with capital repayment amounts of different sizes are used in the calculation in the overall planning period.

As a rule the cumulative cash-flow in the first periods after the initial investments is negative, i.e. the cash-inflow were so far not able to cover or exceed the cash-outflow. The period in which the "cumulated cash-flow" becomes positive can be described to a first approximation as the amortization period.

Fig. 110: Composition and structure of the cash-outflow

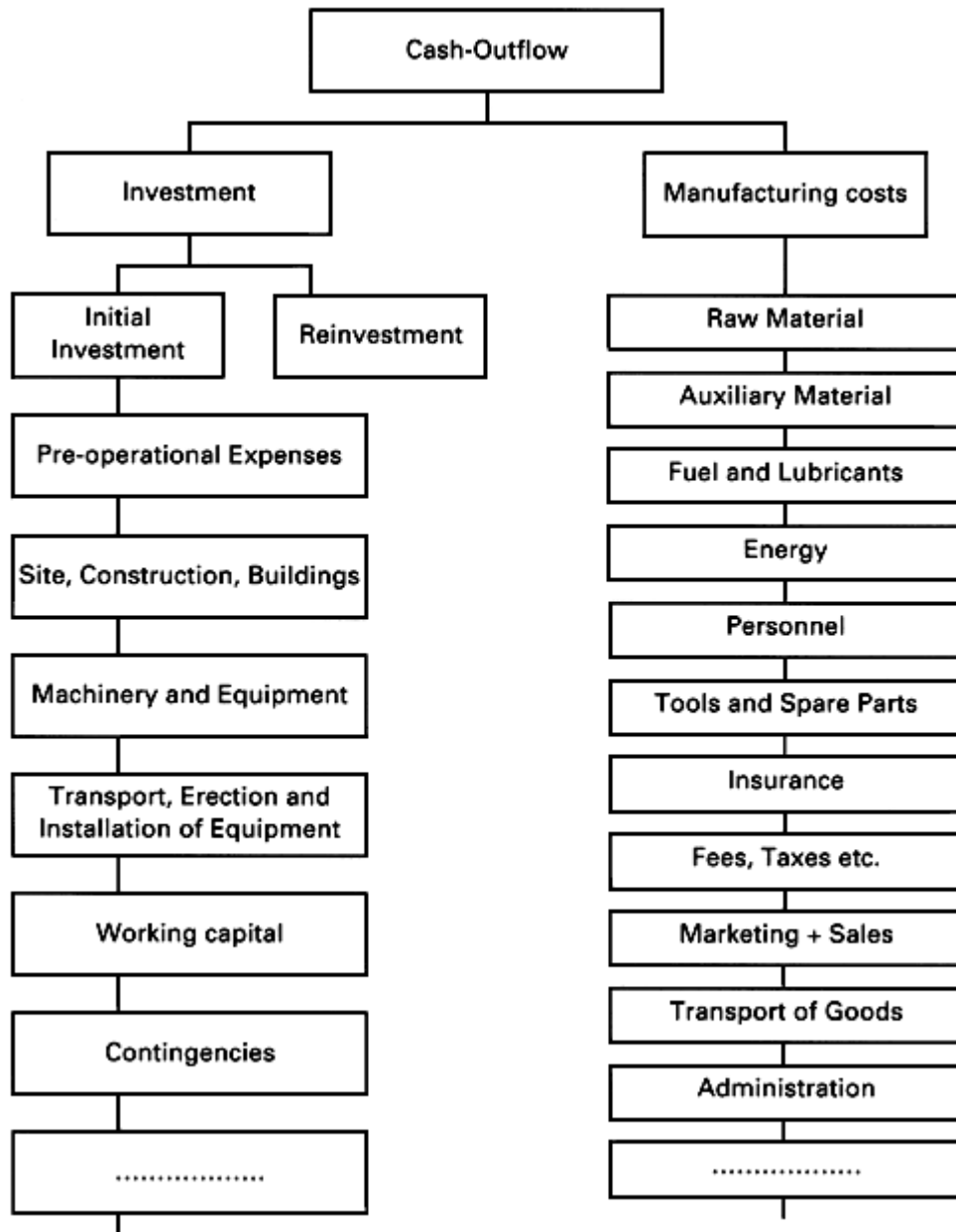

Section 10.3 describes as an example a cash-flow analysis and internal rate of return for a furniture factory producing furniture from coconut palm wood.

10.2 Calculation of costs for cut timber from coconut palm wood

10.2.1 Capacities

1. Basic data

- Average log length: 4.0 m
- Average log diameter: 250 mm (without bark)
- Average log volume: 0.20 m³ (r)
- Working days per year: 300
- Working hours per day: 1 shift of 8 hours = 480 min

2. Cutting principle sawn timber

Fig. 111: Different density boards cut out of a palm stem

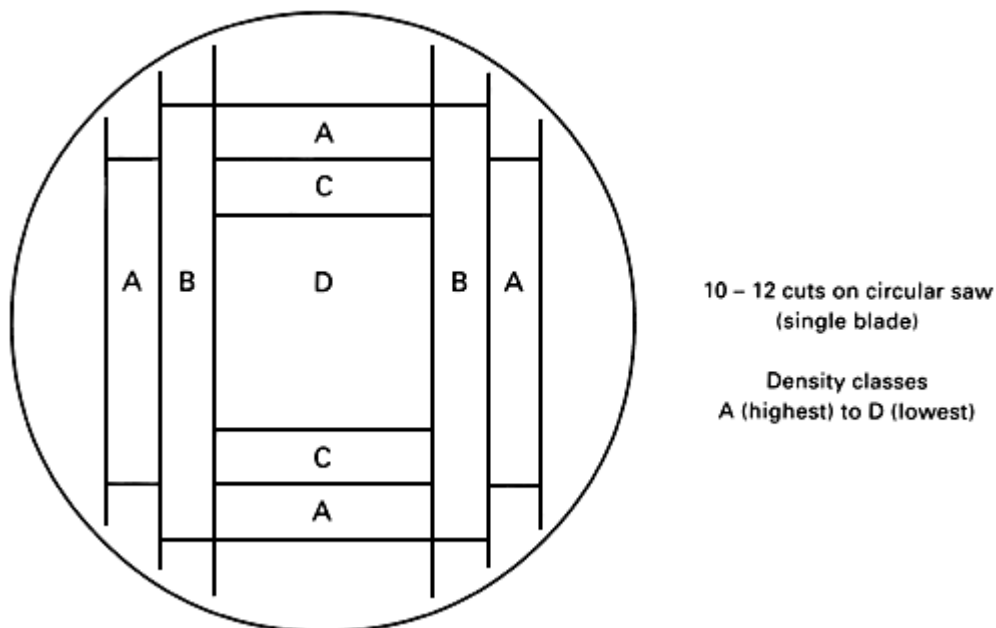

3. Calculation of circular saw capacity

- Effective production time: $\frac{480 \text{ min}}{-60 \text{ min standstill time}} = 420 \text{ min}$
per day
- Cutting time per log: 12 min
- Cutting volume per day: 7 m³ (r)
- Cutting volume per year: 2100 m³ (r)

4. Sawn timber output p.a.

- High density (HD) material (yield 33 %): approx. 700 m³ p.a.
 - Medium density (MD) material (yield 12 %): approx. 250 m³ p.a.
- Total volume of sawn timber:
(+ Firewood approx. 300 m³ p.a.) 950 m³ p.a.

10.2.2 Calculation of manufacturing costs

Table 52: Calculation of manufacturing costs (Output: 950 m³ s.t. p.a.)

Cost item	Costs p.a. (US\$)	Costs p. m³ (us \$)
1.0 Raw material	31,500	33.15
2.0 Auxiliaries		
2.1 Electric energy	7,200	7.58
2.2 Fuel and lubricants	1,600	1.68
2.3 Treatment material	3,700	3.90
3.0 Personnel		
Wages and salaries (incl. social costs)	32,000	33.68
4.0 Maintenance and saw doctoring	5,600	5.90
5.0 Spare parts	5,500	5.80
6.0 Administration and sales	6,100	6.42
7.0 Insurance etc.	3,100	3.26
8.0 Interests	8,000	8.42
9.0 Depreciation	17,500	18.42
(Processing costs pos. 2-9)	90,300	95.06
Total manufacturing costs	121,800	128.21

Excursus: Sawing of different products in a single period

If different types of products are sawn in a single review period, and give rise to different inputs for the different products and thus differing processing costs, then the average processing cost per m³ of sawn timber mentioned above must be allocated according to the cost causation principle.

Example:

Table 53: Processing costs per product type

Type of product	Preportion by volume	Costs factor based on proc costs	Calculation factor regarding volume and proc. costs	Processing costs per product type
Un edged sawn timber	0.2	1.0	0.20	63.8
Edged sawn timber	0.5	1.5	0.75	95.7
Construction timber	0.3	1.8	0.54	114.8
	1.0		1.49	

Subsidiary calculation:

$$\text{Processing costs per calculation unit} = \frac{\text{Average processing costs}}{\text{Calculation factor}} = \frac{95.06}{1.49} = 63.8 \text{ US \$/m}^3 \text{ s.t.}$$

Important

The values of this calculation cannot be transferred to other application cases. They act only as examples. However the methods and systematics of this calculation are generally valid and are transferable !

10.3 Cash-flow analysis and internal rate of return of a coconut palm wood furniture plant

The cash-flow plan for the coconut palm wood furniture plant is calculated for a period of 10 years. It is based on the costs and revenues calculated separately. Investment costs as well as re-investment were considered as follows:

Year "0": Total investment of 4,885 million Indonesian Rp

Year "5": Re-investment of 340 million Rp for equipment in Period 5
(sales/administration)

All calculations are based on constant price levels, since the anticipation of inflation-related increases in cost and revenues would be highly speculative and it may furthermore be assumed that inflation-related effects would counterbalance each other.

The cash-flow plan shows that, except year "0" (initial investment, no production), no negative cash-flow values (cash-outflows) are to be expected, and that a positive cumulative net cash-flow is achieved already after 3.5 years. This means that the payback period is only 3.5 years. The cumulative cash-flow over the observation period of 10 years shows a result of 10,663 million Rp (2 times the initial investment).

The internal rate of return, i.e. the yield on invested capital amounts to 28 % (see Table 54).

	Period 0	Period 1	Period 2	Period 3	Period 4	Period 5	Period 6	Period 7	Period 8	Period 9	Period 10
I. Investment											
Land and buildings	1,320.00										
Equipment and machinery	3,250.00					340.00					
Working capital	315.00										
Total Investment	4,885.00					340.00					
II. Manufacturing Costs											
Materials											
Cocowood		467.25	700.88	934.50	934.50	934.50	934.50	934.50	934.50	934.50	934.50
Boards		67.20	100.80	134.40	134.40	134.40	134.40	134.40	134.40	134.40	134.40
Fittings, screws etc.		78.75	118.13	157.50	157.50	157.50	157.50	157.50	157.50	157.50	157.50
Glue		3.47	5.20	6.93	6.93	6.93	6.93	6.93	6.93	6.93	6.93
Laquer, varnishes		31.61	47.41	63.21	63.21	63.21	63.21	63.21	63.21	63.21	63.21
Total material		648.27	972.41	1,296.54	1,296.54	1,296.54	1,296.54	1,296.54	1,296.54	1,296.54	1,296.54
Auxiliaries											
Electric energy		15.60	23.40	31.20	31.20	31.20	31.20	31.20	31.20	31.20	31.20
Fuel and lubricants		2.15	3.23	4.30	4.30	4.30	4.30	4.30	4.30	4.30	4.30
Packing material		4.75	7.13	9.50	9.50	9.50	9.50	9.50	9.50	9.50	9.50
Total auxiliaries		22.50	33.75	45.00	45.00	45.00	45.00	45.00	45.00	45.00	45.00
Personnel											
Wages, Salaries		286.50	286.50	286.50	286.50	286.50	286.50	286.50	286.50	286.50	286.50
Total personnel		286.50	286.50	286.50	286.50	286.50	286.50	286.50	286.50	286.50	286.50
Other costs											
Maintenance		25.30	25.30	25.30	25.30	25.30	25.30	25.30	25.30	25.30	25.30
Spare parts		25.30	25.30	25.30	25.30	25.30	25.30	25.30	25.30	25.30	25.30
Fees, Taxes		15.75	23.63	31.50	31.50	31.50	31.50	31.50	31.50	31.50	31.50
Insurance		45.70	45.70	45.70	45.70	45.70	45.70	45.70	45.70	45.70	45.70
Sales promotion		49.00	49.00	49.00	49.00	49.00	49.00	49.00	49.00	49.00	49.00
Total other costs		161.05	168.93	176.80	176.80	176.80	176.80	176.80	176.80	176.80	176.80
III. Cash-Outflow II + II)	4,885.00	1,118.32	1,461.58	1,804.84	1,804.84	2,144.84	1,804.84	1,804.84	1,804.84	1,804.84	1,804.84
IV. Cash Inflow (Revenues)											
Local markets		1,225.00	1,312.50	1,750.00	1,750.00	1,750.00	1,750.00	1,750.00	1,750.00	1,750.00	1,750.00
Export markets		525.00	1,312.50	1,750.00	1,750.00	1,750.00	1,750.00	1,750.00	1,750.00	1,750.00	1,750.00
Total Cash Inflow		1,750.00	2,625.00	3,500.00	3,500.00	3,500.00	3,500.00	3,500.00	3,500.00	3,500.00	3,500.00
V. Cash-Flow (IV ./ III)	- 4,885.00	1,163.42	1,163.42	1,695.16	1,695.16	1,355.16	1,695.16	1,695.16	1,695.15	1,595.16	1,695.16
VI. Cum. Net Cash-Flow	- 4,885.00	-3,721.58	-2,558.16	- 863.00	832.16	2,187.32	3,882.48	5,577.64	7,272.80	8,967.96	10,663.12

Table 54: Plan for cash-flow analysis and internal rate of return (IRR)

11 Marketing

Marketing in the present context is understood to mean the entrepreneurial activities and procedures which, directed towards the needs of the market and of the consumer, enable planned production. In the present instance these marketing activities include the introduction and promotion of coconut palm wood as a construction material, and of the products processed from it. Coconut palm wood is still not a commonly traded wood. The opportunities for the application and use of coconut wood for a wide range of products (in this connection see Chapter 2) is still not known to the required extent in many markets to secure an adequate demand for this construction material. The promotion of a "novel" construction material in a comparatively conservative market such as the one for wood and for the products manufactured from it (furniture, doors, parquet etc.) is generally considered to be a difficult and tedious project.

Basically the utilization of coconut palm wood has numerous positive effects and these must be presented, especially in the potential outlet markets:

- Through the utilization of excessively old and unproductive palms, replacement of old plantations and additional sources of income and jobs in the rural area.
- The opportunity to relieve the pressure on tropical rainforests, mainly through wood for the local market.
- Reducing diseases and catastrophes in the plantations (e.g. as a result of the rhinoceros beetle or lethal yellowing) by the purposeful use of old palms.

Being a plantation wood and agricultural by-product, the use of coconut wood from plantations that are too old can be accepted under ecological aspects and must be seen apart from the context of tropical rainforest utilization. This must be made clear to the end-users in the industrialized countries.

Pre-conditions for use and marketing

- An adequate and permanent availability of raw material for continuously supplying the outlet markets.
- The manufacture from coconut palm wood of products whose manufacture and use does not pose any problems. Not all wood products can be manufactured from coconut wood (knowledge of the properties and limitations of the construction material).
- Fulfilment of the quality requirements of the different markets. The manufacture and marketing of products of inadequate quality should be avoided. This brings the construction material into disrepute. It is better to manufacture products with a smaller added value (e.g. parquet instead of furniture) until sufficient know-how is available and/or the correct techniques can be employed.

A fundamental distinction must be made between the local markets in the countries of origin and the export markets, since different demands are imposed on manufacture and marketing.

Local markets

In certain cases the use of coconut wood can replace tropical wood from rain forests. The foremost of these are use as structural material in building, for telephone poles and as fuel wood (waste, slabs, and low density material}. Construction wood with a low level of processing can currently be made available more cheaply than tropical wood from rain forests, especially in the rural area (50 - 60 % of the price of tropical wood).

None of the products mentioned above requires the use of costly technology for its manufacture.

Export markets

The above-mentioned pre-conditions for use and marketing must be ensured, especially when supplying export markets. Obviously the highest possible amount of added value must be aimed at, taking into account the available know-how and technology. In the industrialized countries the palmtree is the symbol for the exotic, sun and vacation. This should be exploited in marketing activities. There are two obvious opportunities for marketing products made from coconut palm wood:

1. Cheap products in large quantities and to some extent a low level of processing, such as sawn timber, pallets, wallpanelling, parquet, packaging material, scantlings timber for doors).
2. Products with a special design and of high quality, such as furniture, finished parquet, accessories, that are offered in the higher (up-market) price sector.

The characteristics of coconut wood that may have impacts on the sales opportunities must be taken into consideration in both product routes. In the first case these include high manufacturing costs that result mainly from high tooling costs and low machine capacities in the machining and which may therefore prevent the provision of economically-priced products. In the second case special account must be taken of the appearance of coconut wood, since it looks very dark when used in large surface areas, i.e. the design must take special account of this effect, e.g. by the use of differently coloured materials (a combination of materials and colours, e.g. through fabrics or differently coloured woods).

Photo 58: Table-top made of various coloured woods incl. coconut palm wood



Tables and Photo by Rapi Furniture, Indonesia

Moreover it must be remembered that certain geometries (e.g. highly prominent profile shapes) cannot be manufactured or are achievable only with a loss of quality. Good design, adapted to the construction material, is therefore an essential marketing factor for products made from coconut palm wood. A professional, strategic approach is indispensable in both cases. A joint venture with a company from a potential sales region would be advantageous for a business that would like to enter into the utilization and marketing of coconut palm wood. As a result of a joint venture of this kind the entrepreneur's technical pre-conditions in situ as well as the market opportunities can be improved by a knowledge of the existing markets and administration structures/instruments.

Companies from Mexico, Jamaica and other tropical countries have attempted in the past to export products made from coconut wood into industrialized countries. These attempts failed because they were not able to fulfil the requirements of the outlet markets through bad product quality and sorting of the wood, pest attack on the wood and lack of knowledge of the markets. The outlet markets and the characteristics of coconut palm wood dictate the framework conditions for the successful utilization of this raw and construction material.

12 Checklist: How to start coconut palm stem utilization

1. Assess age and quality of palms to be felled. The volume to be recovered depends on age and size (height, diameter at breast height) of palms as well as on their quality (insect attack, fungus attack, harvesting steps, straightness of stem).
2. Assess quantity of palms available and their distribution
 - Palms per hectare
 - Area to be felled
 - Distribution of plantations
 - Transport distances.
3. Assess planned felling schedule
 - How many hectares and m³ per year?
 - How are the different felling areas located?
4. Assess ownership
 - Who owns the plantations?
 - What log price can be assumed ?
5. Assess the sales market for coconut wood products
 - Which products can be sold locally?
 - Which products can be exported?
 - What will be the quantities, prices and qualities?
 - Where are the markets?
6. Decide your product range
 - Type
 - Markets
 - Quantity
 - Quality
 - Prices.
7. Assess the assumed production
 - What will be the daily, monthly, annual intake of coconut palm wood in form of logs and m³?
 - What will be the daily, monthly, annual production, quantity (m³) and value?
8. Decide on the marketing of your products
 - Who will market them for you?
9. Assess the execution of different steps of conversion process
 - Who will do the felling and transport?
 - Who will do the sawing, drying and preservation?
 - Who will do the manufacturing?
10. Decide on site of your operation (depends on steps 1-5 and 7 above)
11. Decide on equipment needed dependent on step 6.

12. Assess the personnel needed for operation.
13. Assess the personnel costs (incl. training).
14. Assess the investment costs.
15. Assess the production costs.
16. Assess the costs per produced item.
17. Do step 16 and 5 match?
If yes, look for investor/capital and start operation.

13 Glossary

- absorption - up-take of preservative by timber
- air-drying - natural seasoning of wood in the open air
- air-seasoning - see air-drying
- bite - the distance the timber advances into the saw between each successive tooth
- $$\text{bite} = \frac{\text{feed speed} \times \text{pitch}}{\text{surface speed}}$$
- bow - defect of sawn timber, referring to the percentage of bend in longitudinal direction in relationship to overall length
- breakdown saw - saw to make first cuts (ripping) into the log in order to convert it into sawn timber
- breast bench - circular saw for edging and resawing
- Bucking - cross-cutting of tree trunks to shorter logs
- Butt - lower end of stem
- cambium - wood forming layer of cells between phloem and xylem in trees (except in monocotyledons), immediately under bark, induces the secondary growth of trees
- case hardening - seasoning defect of sawn timber, stress between adjacent layers of wood, which results in warping, when wood is further converted
- cell collapse - seasoning defect of sawn timber, due to improper (too fast) drying. The inner cells of a board collapse and honeycombing occurs
- coir - fibre of coconut husk
- copra - dried meat of coconut
- cortex - exposed outer layer of stem (conventionally bark)
- cover crop - crop planted between palmsto cover the soil and prevent growth of competing vegetation, usually legume which fixes nitrogen to soil
- creosote - oily, black preservative based on coaltar
- cup - seasoning defect of timber, bending of board in transversal direction
- density - relationship of weight over volume of a matter at a given moisture content, given in g/cm³ or kg/m³
- diffusion - tendency of gases to fill related spaces in the same density
- diffusion process - preservation process using the principle of diffusion
- dipping - placing timber for a short time into a preservative solution in order to prevent fungus and insect attack during seasoning
- dipping tank - tank filled with preservative for dipping
- dry bulb - instrument to measure the relative humidity of the air, a dry and wet bulb thermometer and an air velocity of about 2 m/sec are required. The dry bulb thermometer is a normal thermo-meter. See wet bulb.
- edging - ripping (resawing) of sawn boards in order to produce one or two longitudinal edges (cutting off of wane, bark etc.)

empty cell process	- in preservation: also called Rueping process-initial air pressure preservative introduction-higher air pressure-atmospheric air pressure (sometimes vacuum): cell walls are coated with preservative
Equilibrium moisture content	- moisture content developing in a material in a certain climatic environment, depends on temperature and relative humidity
feed per tooth	- the length of the path through which the workpiece moves during cutting between the engagement of two consecutive cutting edges
feed speed	- velocity with which timber is fed into a saw, measured in m/minute fibre saturation
fibre saturation point	- moisture content at which the wood fibres are saturated with water, generally around 30 %, in coconut palm wood at 24 %
frame-saw	- see gangsaw
full cell process	- preservation: application of vacuum-application of pressure: the entire cell is filled with preservative
gangsaw	- machine with various saw-blades sawing parallel to each other and cutting in same motion
grading	- sorting of timber according to its defects and/or later uses
gullet	- area of saw-blade between two teeth carrying the sawdust
harvesting step	- steps hewn in cortex of coconut palms in order to facilitate climbing and harvesting
headrig	- see breakdown saw
high speed steel	- tool steel with high amount of Tungsten (up to 20 %) and carbon
honey combing	- seasoning defect of timber, interior checks appearing on cross sections like honey combs
hook angle	- angle at which the face of the sawtooth contacts the material to be cut
inserted tooth	- throw away tooth which can be inserted into slots in gullets of a circular saw
Janka	- Austrian scientist who established a relationship between hardness and crushing strength of wood and introduced a hardness testing method
jockey grinder	- transportable grinding machine for circular saws, driven by an electrical motor attached, which can be mounted on saw-blade
kerf	- width of wood removed by the saw
kiln-drying	- drying in an oven
legume	- plant which absorbs by symbiosis with bacteria atmospheric nitrogen and fixes it in its tissue
log skid	- log deck, area in sawmill between log-yard and saw
log-yard	- area for dry storage of logs before sawing
man-hour	- work one man can do in one hour
mild steel	- steel with lower carbon content {1-3 %}
monocotyledon	- botanical class under Angiospermae, to which, e.g., all grasses, cereals and palms belong
oven-dry	- bone-dry, 0 % moisture content
parenchyma	- storage tissue in wood

phloem	-	cellsystem for transportation of assimilates
pitch	-	shortest distance between two tooth points
pith	-	innermost portion of stem, core
quartering	-	sawing log into quarters over centre
resaw	-	secondary saw in sawmill for ripping timber coming from headrig and edging
retention	-	amount of preservative kept in wood after treatment (in kg/m ³)
rig	-	set of sawmill equipment
ripping	-	sawing log lengthwise
sap	-	preservation of timber in log form, where preservative is forced into the displacement bole from butt end by pressure and displaces the water in the log. The water is flowing out at the top end
saw doctor	-	specialist trained in sharpening and maintenance of saws
sawgauge	-	thickness of saw-blade
saw guides	-	a supporting device placed on both sides of saw-blade near rim or tooth ground to prevent the saw from deviating of the line while cutting
sclerenchyma	-	hard "skeleton" cells with thick cell walls, often containing silica, which ensheath the vascular bundles in coconut palm stems
seasoning	-	drying
sharpness angle	-	angle in which saw tooth is formed, between tooth face and back
skidding	-	hauling of logs from point of felling to point of loading
skidding bar	-	horizontal steel bar behind tractor with slots to insert skidding chain
slab	-	board cut from the outside of a stem, which due to its curvature (wane) and bark percentage is of no use as sawn timber
spring	-	seasoning defect of sawn timber
stellite	-	alloy of cobalt (40- 50%) with other metals, used for hardening saw teeth
swage	-	shaping of saw teeth by compression to provide equal side clearance on both sides
swage cup	-	dent developed due to swaging
through and through sawing	-	sawing a log with parallel longitudinal cuts
top clearance angle	-	angle between tangent to tooth point and tooth back
tungsten carbide	-	very hard, but brittle alloy with high amount of tungsten, used for saw teeth tips which cut hard woods, particle boards etc.
twist	-	season ing defect, timber is turned a round its longitudinal axis
vascular bundles	-	strands of phloem and xylem cells embedded in paren-chymatous cells and sheathed by sclerenchyma cells which are the transport systems and skeleton of monocotyledons
wane	-	unsquared (round) edge of board, usually with bark
wet bulb	-	see dry bulb: thermometer tip is wrapped in cloth. Evaporation reduces the temperature. Difference dry bulb-wet bulb indicates the relative humidity
xylem	-	cell system transporting the water through the stem

14 List of Tables

- Table 1: Palm stem data (at 60 years of age)
- Table 2: Mechanical properties of coconut wood, 12 % me
- Table 3: End-uses for coconut wood
- Table 4: Design guidelines for industrially manufactured products
- Table 5: Data on circular sawmill for coconut wood conversion
- Table 6: Daily recovery rate from circular sawmills
- Table 7: Technical data of different saws
- Table 8: Advantages and disadvantages of different saws
- Table 9: Comparison of cutting steels
- Table 10: Coconut wood deflection chart
- Table 11: Formulas for moisture content assessment
- Table 12: Recommended sticker sizes (mm) and distribution
- Table 13: Air-drying time for coconut sawn timber (to 18 - 19 %) in weeks
- Table 14: Kiln atmospheric conditions for 50 mm boards
- Table 15: Kiln atmospheric conditions for boards 25 mm and thinner (from green}
- Table 16: Kiln-drying schedule for pre-air-dried coconut sawn timber, 50 mm, initial moisture content 40 - 50 %
- Table 17: Kiln-drying schedule for fresh coconut sawn timber, 25 mm
- Table 18: Advantages and disadvantages of drying methods
- Table 19: Soaking time for hot and cold bath (water/CCA)
- Table 20: Preservation schedule
- Table 21: Cutting speeds for solid wood
- Table 22: Tolerances on the machine
- Table 23: Tool construction types
- Table 24: Tool tolerances
- Table 25: Favourable values for feed per tooth f_z (= length of cutting marks) when circular sawing coconut palm wood
- Table 26: TCT circular saw blades for machining coconut palm wood
- Table 27: Circular saw machines and their application
- Table 28: Technical data for circular sawing Cocos n. parallel and perpendicular to the grain
- Table 29: Machining coconut palm wood with band-saw blades
- Table 30: Technical data for band-sawing
- Table 31: Surface quality
- Table 32: Cutting angles when planing and moulding coconut palm wood with TC blades
- Table 33: Planing machines and their application
- Table 34: Technical data for planing

- Table 35: Tool angle when shaping coconut palm wood with TC knives
- Table 36: Machines for shaping/moulding
- Table 37: Technical data for moulding
- Table 38: Technical data for shaping
- Table 39: Technical data for sanding
- Table 40: Tool angles when mortising and tenoning coconut palm wood with TC blades
- Table 41: Technical data for mortise and tenon cutting with slot and tenon cutters
- Table 42: Technical data for (straight) longitudinal turning
- Table 43: Sawing - Parallel and perpendicular to the grain in Cocos n.
- Table 44: Narrow band-sawing
- Table 45: Planing
- Table 46: Moulding/profiling
- Table 47: Shaping/moulding
- Table 48: Sanding
- Table 49: Mortising and tenoning with slot and tenon cutters
- Table 50: Straight lathe-turning
- Table 51: Model of a cash-flow analysis
- Table 52: Calculation of manufacturing costs (Output: 950 m³ s,t. p.a.)
- Table 53: Processing costs per product type
- Table 54: Plan for cash-flow analysis and internal rate of return (IRR)

15 List of Figures

- Figure 1: Schematic density distribution in mature coconut palm stem
- Figure 2: Use of the coconut palm stem
- Figure 3: Cross section of coconut palm stem with density zones
- Figure 4: Harvesting steps in coconut palm stem
- Figure 5: Principle of a dowelled joint
- Figure 6: Butt-dowelled frame corner
- Figure 7: Dowelled mitred frame corner
- Figure 8: Principle of a tongue and groove joint
- Figure 9: Tongue and groove joint with inserted tongue
- Figure 10: Glue-bonded profile for full-width bonding
- Figure 11: Vascular bundles in longitudinal, transverse and diagonal section
- Figure 12: Felling of coconut palms
- Figure 13: Bulldozing through palm roots
- Figure 14: Skidding behind horse
- Figure 15: Marking of logs in field
- Figure 16: Skidding bar
- Figure 17: Skidding by tractor
- Figure 18: Bucking of coconut palm stems
- Figure 19: Cutting pattern for coconut logs
- Figure 20: Additional pattern for cutting purloins
- Figure 21: Cutting pattern for beams
- Figure 22: Cutting pattern relative to selection and grading
- Figure 23: Cutting pattern for conventional sawmills
- Figure 24: Cutting pattern for frame-sawing
- Figure 25: Fixing of coconut log for handsawing
- Figure 26: Manual sawing of coconut logs
- Figure 27: Two-man ripsaw for coconut palm logs
- Figure 28: Sawing coconut logs by chain-saw
- Figure 29: Solid tooth nomenclature
- Figure 30: Deflection grader for coconut wood
- Figure 31: Simple deflection grader
- Figure 32: Keylwerth-chart for assessment of wood moisture content
- Figure 33: Timber stack with pressure clamps
- Figure 34: Possible arrangement for drying stacks
- Figure 35: Foundation of stack with coconut round wood, squared on two sides
- Figure 36: Stacking of short pieces of wood
- Figure 37: Timber stacking - in pile
- Figure 38: Solar dryer - glasshouse type

- Figure 39: Solar dryer - collector type
- Figure 40: Convection dryer
- Figure 41: Condensation dryer
- Figure 42: Seasoning defects in coconut wood
- Figure 43: Debarking of coconut poles
- Figure 44: Termite shield
- Figure 45: Manufacture of coconut fence posts
- Figure 46: Charring of pole
- Figure 47: Charring of larger number of poles
- Figure 48: Vessel for soaking
- Figure 49: Soaking of poles in hot preservative
- Figure 50: Hot and cold bath for impregnation of power poles
- Figure 51: Debarked poles stacked for drying
- Figure 52: Frame door with panelling
- Figure 53: Working sequence for frame components (vertical side-members, rails)
- Figure 54: Working sequence for the solid wood panelling of a frame door
- Figure 55: Working sequence for assembling a frame door
- Figure 56: Chair back leg
- Figure 57: Working sequence for a chair back leg
- Figure 58: Parquet block
- Figure 59: Working sequence for a parquet block
- Figure 60: Turned component
- Figure 61: Working sequence for turned components
- Figure 62: Table-top
- Figure 63: Working sequence for a laminated table-top
- Figure 64: Effects on surface quality
- Figure 65: Cutting along grain or with grain
- Figure 66: Cutting against grain
- Figure 67: Cross-cutting at right-angles to the grain
- Figure 68: Cutting in end grain
- Figure 69: Pre-splitting during up-cutting
- Figure 70: Chip thickness limitation
- Figure 71: Operating principle of sawing - parallel to the grain (left) and sawing - perpendicular to the grain (right)
- Figure 72: Working sequence for prismatic parts
- Figure 73: Principle of the circular saw cut (Ettelt, 1987)
- Figure 74: Cutting angles - circular saw-blade (see also Figure 29)
- Figure 75: TC tooth shapes
- Figure 76: Use of a stop-block

- Figure 77: Operating principle of narrow band-sawing (sawing of curved or irregularly shaped outlines)
- Figure 78: Technical parameters of band-saw blades
- Figure 79: Table mouth piece
- Figure 80: Working principle of planing
- Figure 81: Parameters on the chip in peripheral planing
- Figure 82: Graph of the theoretical length of cutter marks/feed speed/surface quality
- Figure 83: Actual length of cutter marks
- Figure 84: Hydraulic clamping
- Figure 85: Operating principle of moulding - parallel to the grain (left) and - perpendicular to the grain (right)
- Figure 86: Principle of copy-shaping with a copying pin and template
- Figure 87: Principle of copy-shaping with a roller collar and template
- Figure 88: Multi-stage profile shaping
- Figure 89: Operating sequence in shaping/moulding to avoid tearing of wood
- Figure 90: Form shaping
- Figure 91: Groove shaping with a shank type cutter
- Figure 92: Operating principle of end-face planing
- Figure 93: Preventing ragged edges when end-face planing by a suitable counter-stop
- Figure 94: Operating principle of boring
- Figure 95: Through hole (left), blind hole (right)
- Figure 96: Twist bit (Ettelt, 1987)
- Figure 97: Operating principle of sanding
- Figure 98: Chip removal during sanding
- Figure 99: Wide belt sanding set with pressure bar
- Figure 100: Operating principle of mortising and tenoning preceded by a dimensioning saw
- Figure 101: Operating principle of swing chisel mortising
- Figure 102: Three-part swing chisel mortising tool
- Figure 103: Construction and principle of the single-part oscillating chisel mortising tool
- Figure 104: Operating principle of straight (plain) lathe-turning
- Figure 105: Cutting angles and edges on lathe chisels
- Figure 106: Diagram of the principle of a bell-shaped knife
- Figure 107: Design of glue-bonded profiles
- Figure 108: Charcoal kiln "markV"
- Figure 109: Profitability
- Figure 110: Composition and structure of the cash-outflow
- Figure 111: Different density boards cut out of a palm stem

16 List of Photos

All photos, if not mentioned otherwise, have been taken in the Philippines, mostly in Zamboanga. The wood shown is all coconut wood.

- Photo 1: Cross section of coconut palm stem at breast height
- Photo 2: Low-cost house
- Photo 3: Handplaning of coconut beam for low-cost house construction
- Photo 4: Coconut pavilion roofed with coconut shingles
- Photo 5: Roof construction of coconut chapel in Davao, Philippines
- Photo 6: Bungalow with coconut wood - the pillars are hollow cylinders
- Photo 7: Detail of wall with bricks made of coconut sawdust and wall-panelling
- Photo 8: Details of coconut wood house (window frames)
- Photo 9: Turned balusters
- Photo 10: Chair
- Photo 11: Laminated table-top
- Photo 12: Briefcase
- Photo 13: Dining-room table and chairs (Pacific Green, Fiji)
- Photo 14: Coconut wood - upholstered furniture (Pacific Green, Fiji)
- Photo 15: Living-room furniture and accessories (Pacific Green, Fiji)
- Photo 16: Coconut palm wood furniture exhibited at International Furniture Fair in Cologne, 1994
- Photo 17: Coconut palm wood furniture exhibited at International Furniture Fair in Cologne, 1994
- Photo 18: Tool handles
- Photo 19: CCA-treated fence post
- Photo 20: CCA-treated power pole
- Photo 21: Fungal attack on untreated power pole
- Photo 22: Crates
- Photo 23: Laminated and bolted coconut boards
- Photo 24: Laminated roof trusses joined by a nail plate
- Photo 25: I-beam with plywood webbing
- Photo 26: Laminated and bolted roof construction
- Photo 27: Coconut palm stems after toppling
- Photo 28: Manual ramp-loading of palm logs
- Photo 29: Chain-sawing of palm stems
- Photo 30: Chain-sawing of palm stems with guide bar
- Photo 31: Circular saw headrig (note the wide gullets in saw-blade)
- Photo 32: Band-saw
- Photo 33: Frame-saw (infeed)
- Photo 34: Frame-saw (outfeed)

- Photo 35: Frame-saw blade
- Photo 36: Band-saw blade grinder
- Photo 37: Sawdust accumulation under circular saw
- Photo 38: Coconut sawn timber laid out for visual grading
- Photo 39: Stacked coconut boards {note fungus-infected board, second from right)
- Photo 40: Coconut sawn timber stacks in the open (uncovered)
- Photo 41: Sawn timber sheds
- Photo 42: Dip treatment of coconut boards
- Photo 43: Hot and cold bath
- Photo 44: Pressure plant
- Photo 45a: Solid (one-piece) saw-blade
- Photo 45b: TCT-saw-blade
- Photo 46: Dimension saw (sliding table saw)
- Photo 47: Narrow band-sawing machine
- Photo 48: Four-side planing/moulding machine
- Photo 49: Cutter with cutting tips of stellite or TC
- Photo 50: TC-tipped shank type cutter for router
- Photo 51: Profile cutter head with exchangeable knives
- Photo 52: Spindle shaper/moulder
- Photo 53: End-face planing machine
- Photo 54: Boring machine with swivellable boring head
- Photo 55: Profile sanding tool
- Photo 56: Operating principle of dovetailing
- Photo 57: Charcoal kiln "mark V"
- Photo 58: Table-top made of various coloured woods incl. coconut palm wood

17 Abbreviations

a	-	clearance angle
abs	-	absorption
a _e	-	cutting depth
av	-	average
b	-	wedge angle
BWG	-	Birmingham wire gauge, British standard for measuring thickness of wires and sheetmetal
C	-	Celsius, or Centigrade {see also Fahrenheit!
CCA	-	Copper-Chrome-Arsenate, water-borne preservative
cm	-	centimeter
cm ²	-	square centimeter
CN	-	Chromium-Nickel
Cocos n.	-	Cocos nucifera L.
D	-	diameter
dbh	-	diameter at breast height
deg	-	degree (°)
Dia	-	diameter
emc	-	equilibrium moisture content, moisture content (mc) reached and held at given temperature and relative humidity of air
F	-	Fahrenheit, °F = 1.8x°C + 32
FAO	-	Food and Agriculture Organization of the United Nations
fig	-	figure
ft	-	foot
fz	-	feed per tooth
g	-	gram
γ	-	rake angle
H	-	hour
ha	-	hectare
HD	-	high density coconut palm stem material
hp	-	horse power, 1 hp = 0.75 kW
HSS	-	high-speed steel
J	-	Joule
KD	-	kiln-drying
kg	-	kilogram
kPa	-	kilopascal
kW	-	kilowatt
L	-	length
LD	-	low density coconut palm stem material

M	-	meter
M ³	-	cubic meter
max.	-	maximum
me	-	moisture content (in % of dry matter)
mci	-	initial moisture content
MD	-	medium density coconut palm stem material
min	-	minute (s)
min ¹	-	rpm, revolution per minute
mm	-	millimeter
mN	-	meter newton
MoE	-	modulus of elasticity
MoR	-	modulus of rupture
MPa	-	megapascal
MS	-	mild steel
N	-	newton
n	-	tool rotational speed
n.a.	-	not assessed
NAPCP	-	Sodium Pentachlorophenate
r.p.m.	-	revolutions per minute
t	-	temperature, here also: dry bulb temperature
t&g	-	tongue and groove
TC	-	tungsten carbide
TCT	-	tungsten carbide tipped
th	-	thickness
tw	-	wet bulb temperature
V _c	-	cutting speed
V _f	-	feed speed
w	-	width
we	-	current weight
wd	-	dry weight
wod	-	ovendry weight (at 0 % mc)
ww	-	wet weight
z	-	number of cutting edges

18 Literature cited

- Argyropoulos, G. A., 1991.** Schleifen plattenformiger Werkstucke, Kassel.
- Astell, A. S., 1981.** The primary conversion of coconut stems into sawn timber. Working Document PHI/71/523. Philippines, FAO/UNDP.
- Brion, H., 1984.** Demonstration of coconut wood utilization in low cost housing UNIDO, SI/Phi/83/801.
- Desch, H. E., 1981.** Timber, its structure, properties and utilization. 6th rev. ed. Mac Millan Press Ltd., London, 410 pp.
- Ettelt, B., 1987.** Sägen, Fräsen, Hobeln, Bohren, Stuttgart.
- FAO, 1985.** Coconut wood. Processing and use. FAO Forestry Paper 57, Rome, 58 pp.
- Fink, D., Heuer, M., 1991.** Spanende Bearbeitung von Kokospaimenholz, Fachhochschule Rosenheim, unpublished.
- Frühwald, A., Peek, R. D. and Schulte, M., 1992.** Utilization of Coconut timber from North Sulawesi, Indonesia. GTZ, Hamburg, 352 pp.
- Hildebrand & Söhne, 1979.** Handbuch für Holztrocknung. Stuttgart
- Jensen, P., 1981.** Skidding bar. Proceedings Coconut Wood - 1979, Manila-Zamboanga: 67 - 75.
- Jensen, P., 1981.** Machine costs for tractors, timber jacks and equipment. Proceedings Coconut Wood - 1979, Manila-Zamboanga: 197 - 206.
- Jensen, P., 1981.** Recovery in sawn timber from cocos nucifera logs. Proceedings Coconut Wood - 1979, Manila-Zamboanga: 88 - 90.
- Jensen, P., 1981.** Technical information on sawmills. Proceedings Coconut Wood 1979, Manila-Zamboanga: 90-97.
- Jensen, P., Killmann, W., 1981.** Utilization of coconut palm wood (Cocos nucifera L.) Proceedings Coconut Wood - 1979, Manila-Zamboanga: 75 - 79.
- Jensen, P., Killmann, W., 1981.** Production costs of sawn coconut timber. Proceedings Coconut Wood - 1979, Manila-Zamboanga: 207 - 240.
- Juson, R. A., 1983.** Machining of coconut wood. Third PCARRD SMARC coordinated review and evaluation of ongoing and completed research projects. Kabacan, Cotabato, Philippines.
- Juson, R. A., 1984.** The Production of Coconut Lumber Sawing and Sawing Facilities. Philippine Coconut Authority, Zamboanga Research Centre Subject, Handout No. 2A (L).
- Juson, R. A., 1984.** Layout and Yard Facilities for a Permanent Cocowood Sawmill. Philippine Coconut Authority, Zamboanga Research Centre. Handout No. 2B (L).
- Killmann, W., 1983.** Some physical properties of the coconut palm stem. Wood Science and Technology Journal 17: 167 -85.
- Killmann, W., 1988.** Howto process coconut palm wood. Vieweg, Braunschweig, 76 p.
- Killmann, W., Wong, W. C. and Khozirah, S., 1989.** Utilization of palm stems and leaves. Bibliography, 1182 entries. Research Pamphlet no. 103, FRIM, Kepong.

Kininmonth, J. A., 1979. Some physical properties of coconut wood. Proceedings Coconut Wood - 1979, Manila-Zamboanga: 141 - 49.

Leitz (Editor), 1992. Maschinenwerkzeuge für die Holzbearbeitung, Landsberg.

Lockyear, Ross, 1983. Coconut Timber Utilization Manual. Prepared for the Republic of Kiribati. New Zealand Bilateral Aid Programme.

Meier, J., 1991. Untersuchungen zum Trocknungsverhalten von Kokospalmenholz. Diploma Thesis, University Hamburg, 99 pp., unpubl.

Nutsch, Wolfgang, 1983. Handbuch der Konstruktion, Stuttgart.

Palomar, R. N., 1980. Charcoal making. PCA-Zamboanga Research Centre. Unpublished.

Palomar, R. ISI., 1986. Preservation of sawn coconut timber by boron diffusion treatment. CORDII(I): 12-35.

Philippine Coconut Authority, 1977. Preparation and treatment of coconut stem for fencing. Coconut Wood Utilization Division, Zamboanga Research Centre Report.

Quinones, D. G., et al., 1983. Backyard Lumbering of Coconut Trunks with Two-Man Rip Saw. FPRDI Journal XII, 1 and 2, Philippines, 7-15.

Rossmann, S., 1984. Paimwood-Aesthetic Value and Design, in: Palmwood News 1/94, Eschborn

Schulte, M., 1991. Vergleich verschiedener Verfahren zur Sortierung von Kokospalmenholz. Diploma Thesis, University Hamburg, 154 pp, unpubl.

Schulte, M., 1992. Sortierung von Kokospalmenholz mit Hilfe des Finnograder. BFH Hamburg, 20 pp, unpubl.

Sherlock, F. E., 1991. Machine Woodworking Technology, Hertford.

Sulc, V. K., 1981. Coconut wood lamination. Proceedings Coconut Wood - 1979, Manila-Zamboanga: 156-66.

Sulc, V. K., 1983, 1. Draft report on grading rules for coconut palm sawn wood. Regional Coconut Wood Training Programme (RAS/81/110). Zamboanga, Philippines (unpublished).

Sulc, V. K., 1983, 2. Draft report on grading of coconut palm sawn wood. Regional Coconut Wood Training Programme (RAS/81/110). Zamboanga, Philippines (unpublished).

Sulc, V. K., 1983, 3. Draft Report on mechanical properties of coconut palmwood. Regional Coconut Wood Training Programme (RAS/81/110) FAO/UNIDO, Zamboanga, Philippines (unpublished).

Sulc, V. K., 1984, 1. Drying sawn coconut paimwood. Technical report No. 2, RAS/81/110/COIV12andTCP/RAS/4401(T)UNIDO/FAO, Zamboanga, Philippines (unpublished).

Sulc, V. K., 1984, 2. Coconut palm wood utilization. FAO Regional Coconut Wood Training Programme (RAS/81/100). Zamboanga, Philippines (unpublished). **USDA.** Lake States Aspen Report No. 5.

Willeitner, H., Liese, W., 1992. Wood protection in tropical countries. GTZ, Eschborn, 228 pp.